

| REVISIONS |     |         |                  |          |     |       |
|-----------|-----|---------|------------------|----------|-----|-------|
| ZONE      | REV | ECN     | DESCRIPTION      | DATE     | OWN | APPVD |
|           | A   | 1169809 | ORIGINAL RELEASE | 03/15/17 | RCW | NP    |

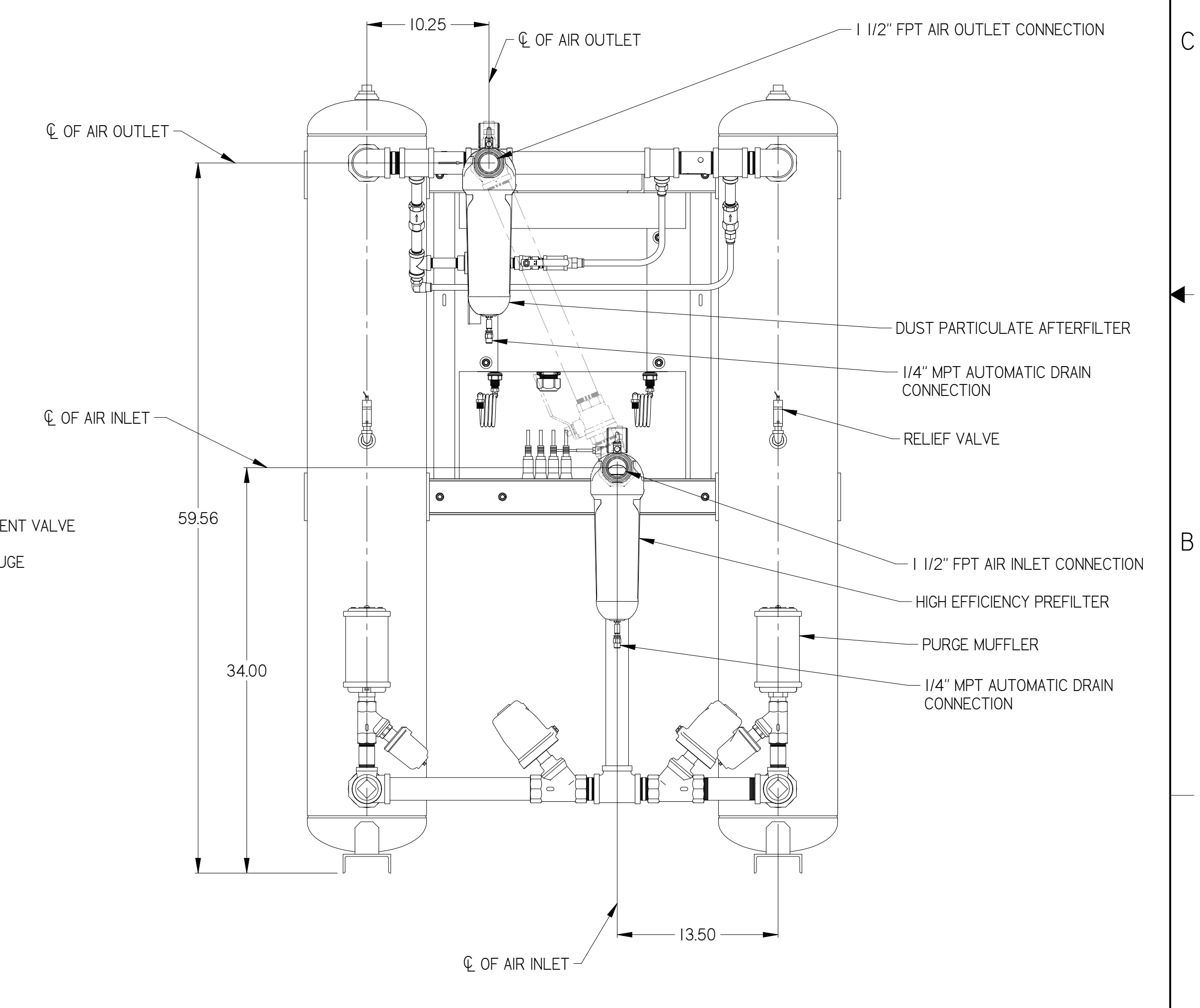
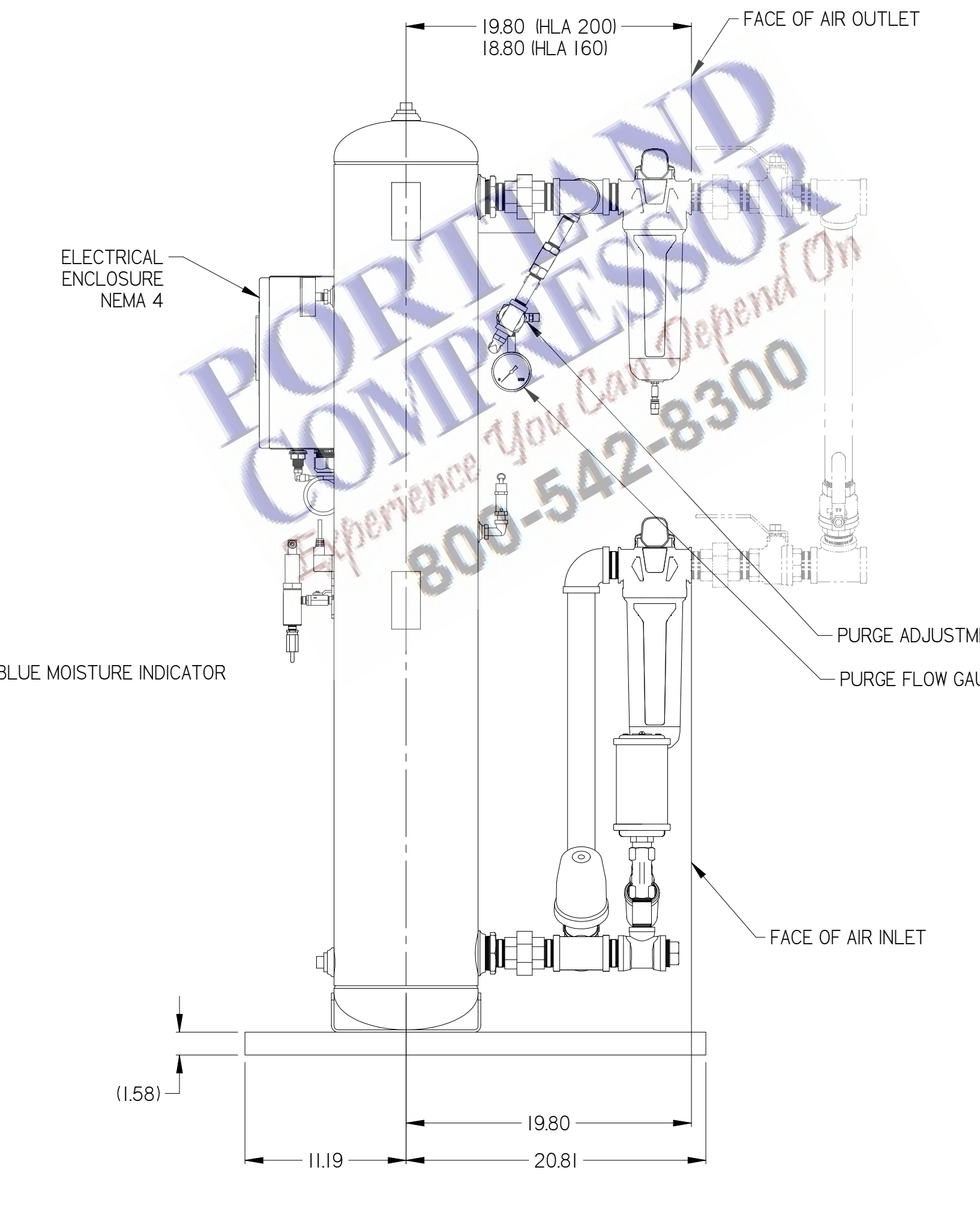
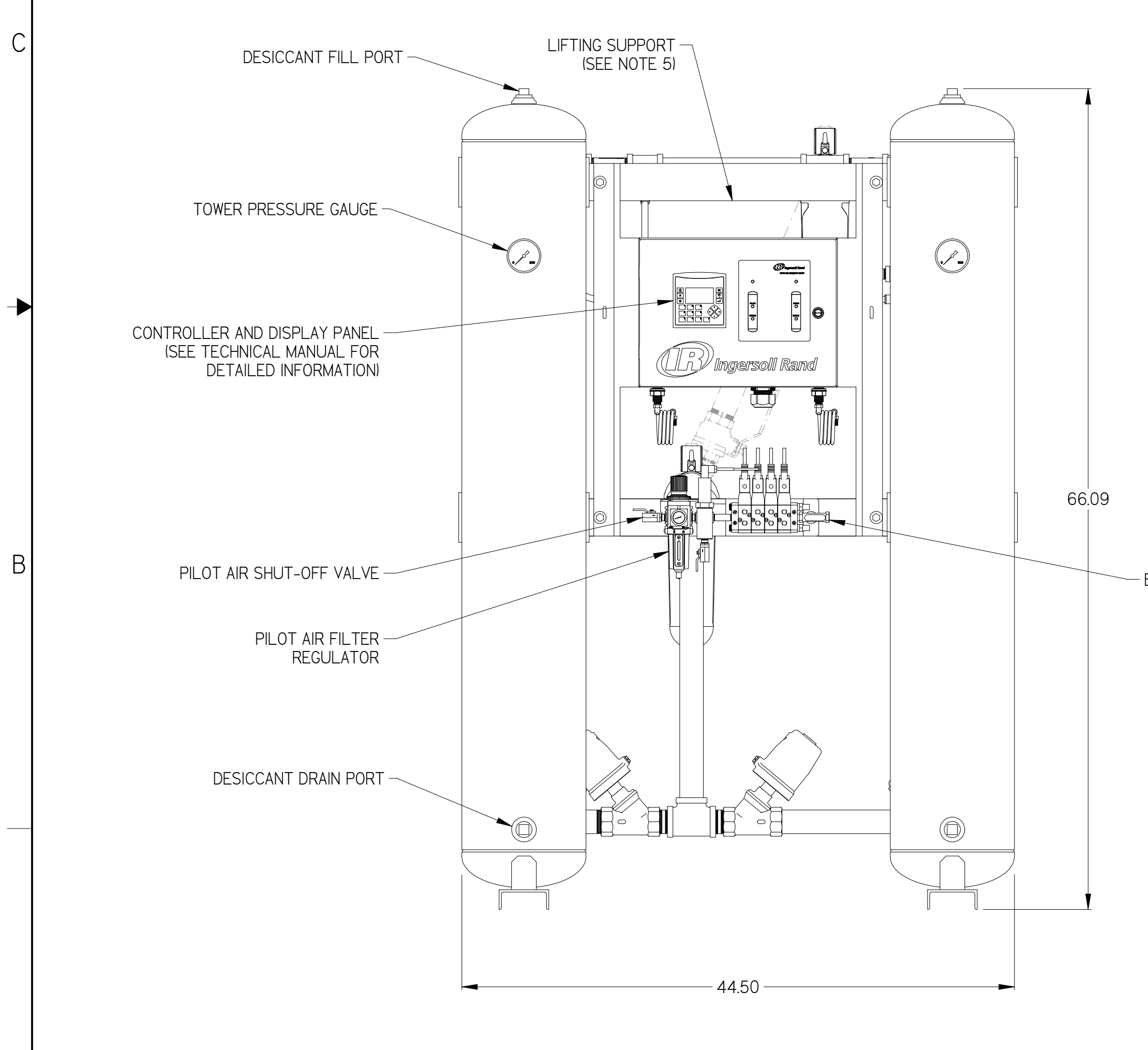
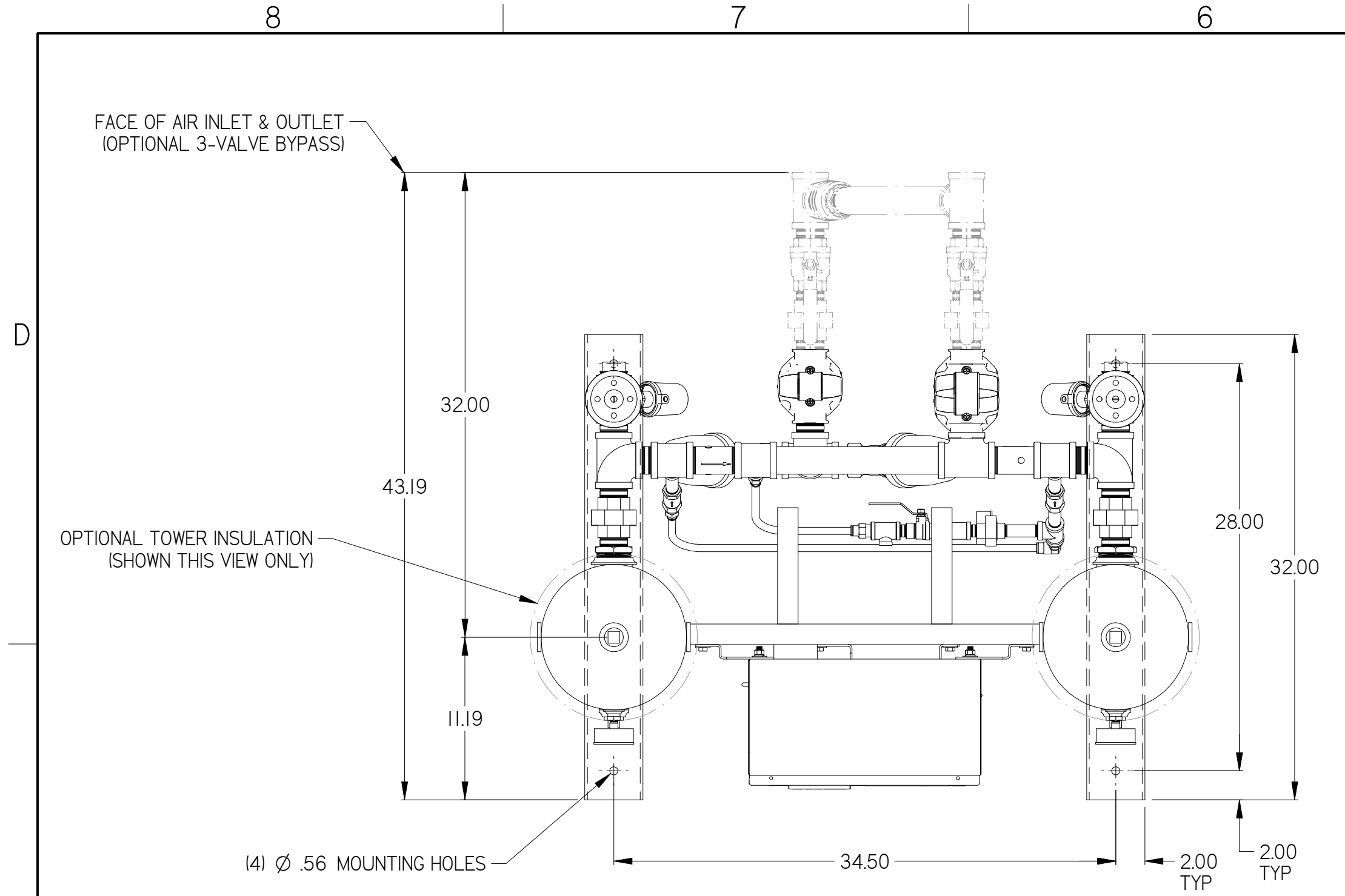

**NOTES:**

- 1) MAXIMUM WORKING PRESSURE - 150 P.S.I.
- 2) SAFETY RELIEF VALVE SETTING - 165 P.S.I.
- 3) PILOT AIR LINES NOT SHOWN FOR CLARITY.
- 4) ALL WIRING IS IN ACCORDANCE WITH THE NATIONAL ELECTRICAL CODE'S LATEST EDITION.
- 5) DRYER TO BE LIFTED BY LIFTING SUPPORT ONLY.
- 6) DESIGN IS DEPICTED FOR STANDARD MODEL. THIS DRAWING DOES NOT DEPICT OPTIONS.
- 7) THE UNIT DIMENSIONS WILL VARY FOR PRODUCTS CONFIGURED WITH OPTIONS.
- 8) THIS DRAWING IS PROVIDED FOR REFERENCE PURPOSES ONLY.
- 9) DESIGN AND DIMENSIONS ARE SUBJECT TO CHANGE WITHOUT NOTICE.
- 10) LOCATION OF COMPRESSED AIR INLET & OUTLET CONNECTIONS MAY VARY BASED ON OPTIONS SELECTED.

|   |   |  |  |                      |
|---|---|--|--|----------------------|
| UNLESS OTHERWISE SPECIFIED, ALL DIMENSIONS ARE IN INCHES, TOLERANCES ARE:<br>FRACTIONS ± 1/2<br>DECIMALS ± .50<br>ANGLE ± 2.5° ± .XXX | PROPRIETARY NOTICE<br>THIS DRAWING CONTAINS CONFIDENTIAL AND TRADE SECRET INFORMATION, IS THE PROPERTY OF INGERSOLL-RAND CO., AND IS GIVEN TO THE RECEIVER IN CONFIDENCE. THE RECEIVER BY RECEPTION AND RETENTION OF THE DRAWING ACCEPTS THE DRAWING IN CONFIDENCE AND AGREES THAT, EXCEPT AS AUTHORIZED IN WRITING BY INGERSOLL-RAND CO. IT WILL (1) NOT USE THE DRAWING OR ANY COPY THEREOF OR THE CONFIDENTIAL OR TRADE SECRET INFORMATION THEREIN; (2) NOT COPY THE DRAWING; (3) NOT DISCLOSE TO OTHERS EITHER THE DRAWING OR THE CONFIDENTIAL OR TRADE SECRET INFORMATION THEREIN; AND (4) UPON COMPLETION OF THE NEED TO RETAIN THE DRAWING, OR UPON DEMAND, RETURN THE DRAWING, ALL COPIES THEREOF, AND ALL MATERIAL COPIED THEREFROM. | REMOVE ALL BURRS AND SHARP CORNERS                 | NOUN CODE  |                      |
|   | DO NOT SCALE  | CAD GENERATED DRAWING, NO MANUAL REVISIONS ALLOWED | THIRD ANGLE PROJECTION<br>DRAWN: RCW<br>CHECKED:<br>APPROVED: NP |                      |
| COPYRIGHT © 2006 INGERSOLL-RAND COMPANY ALL RIGHTS RESERVED   |   | TITLE: GENERAL ARRANGEMENT HLA160 - HLA200         |  | REVISION: A          |
|   |   | SIZE: B  | ESTIMATED WEIGHT: 8.2  | DRAWING NO: 47597094 |
|   |   | CORE: 8.2  | UNIT:  | SHEET: 1 OF 1        |