

Ed.	Rev.	Description	Date	Intr./Appr.
00.00		SEE REVISION 01 NOTES	09/22	JW

REVISION 01 NOTES:
 1) NOTE PERTAINING TO ALTERNATE BELT GUARD ADDED.
 2) DIMENSION OF ALTERNATE BELT GUARD ADDED.

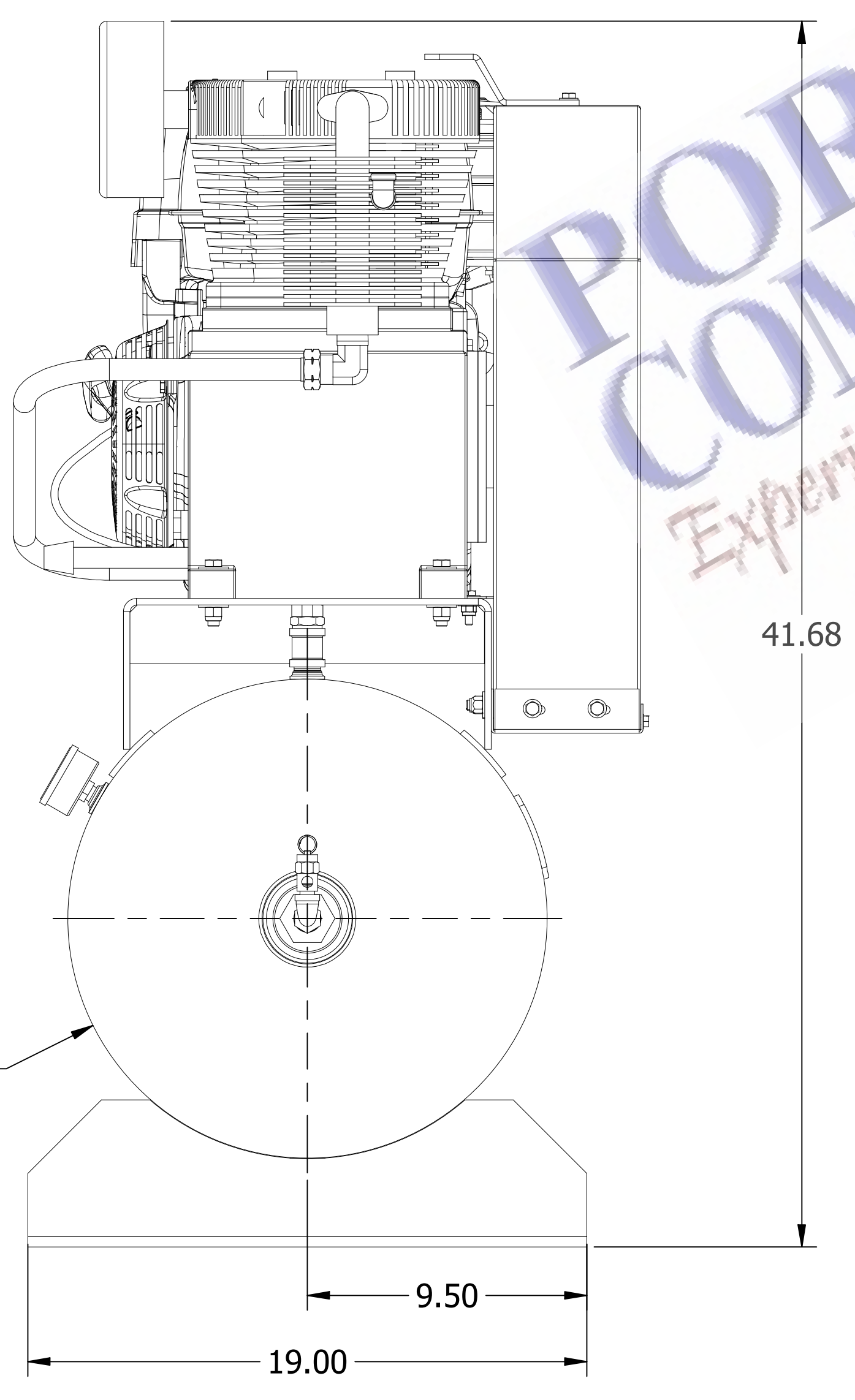

PORTLAND COMPRESSOR
Experience You Can Depend On
 800-542-8300

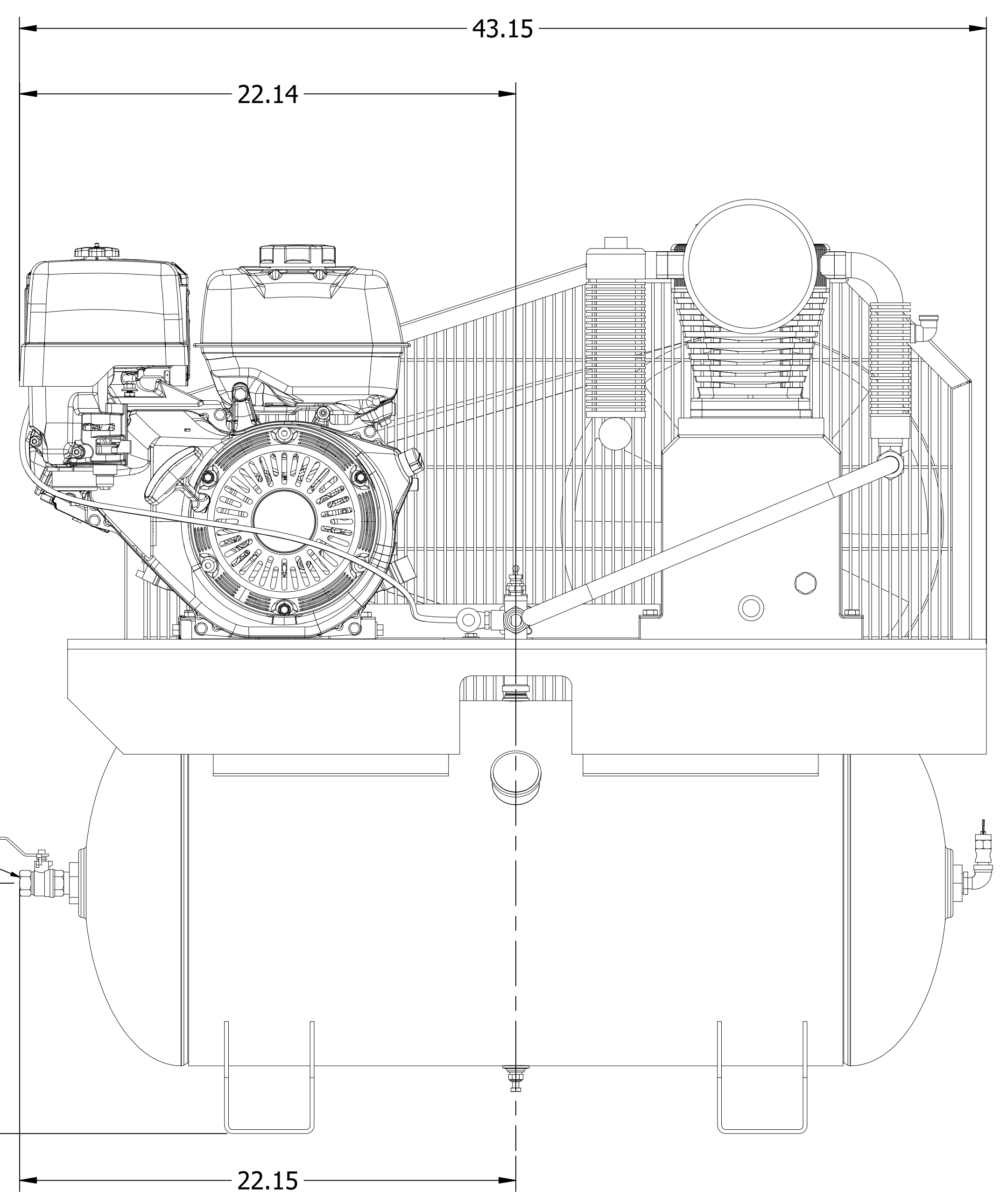
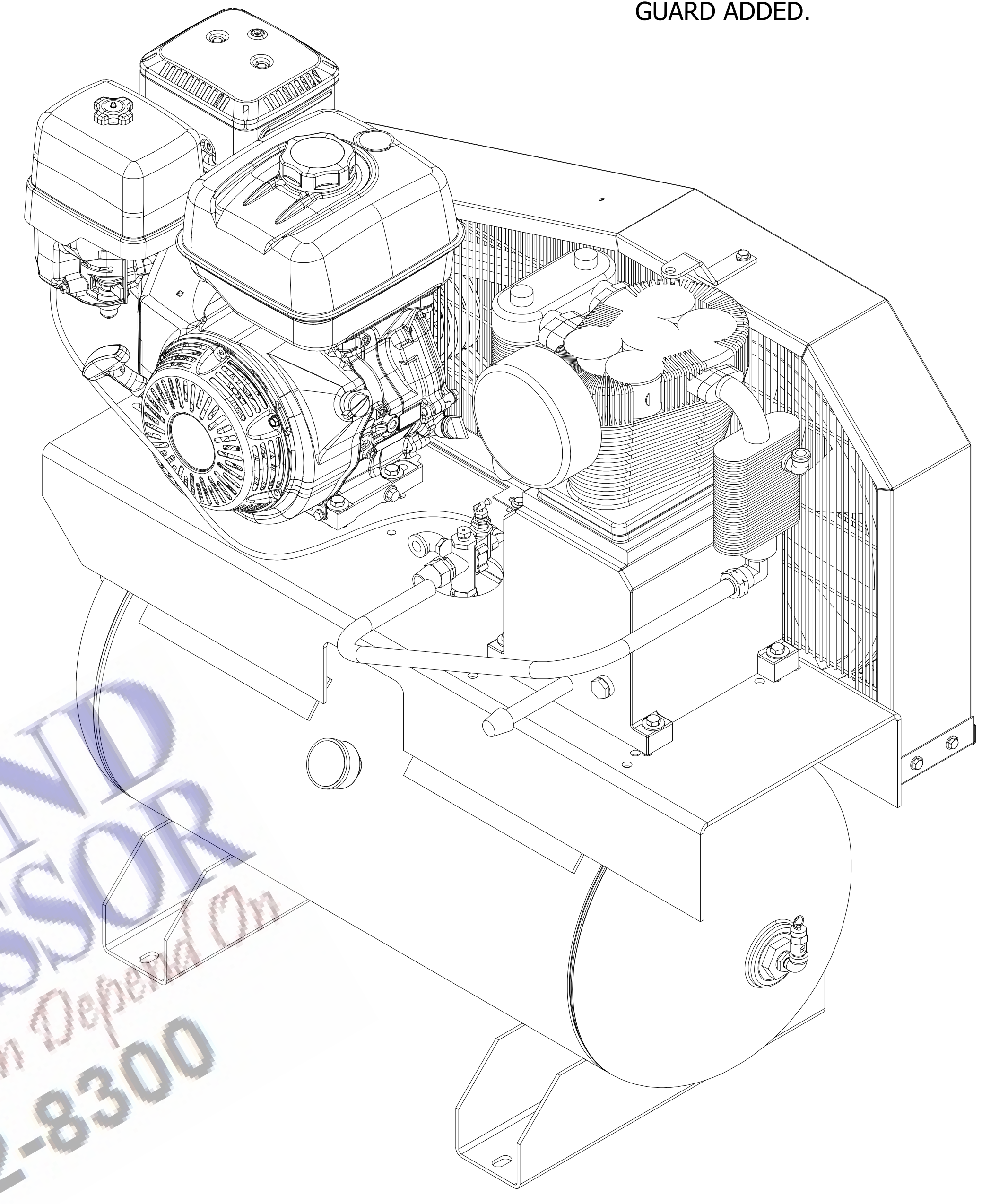
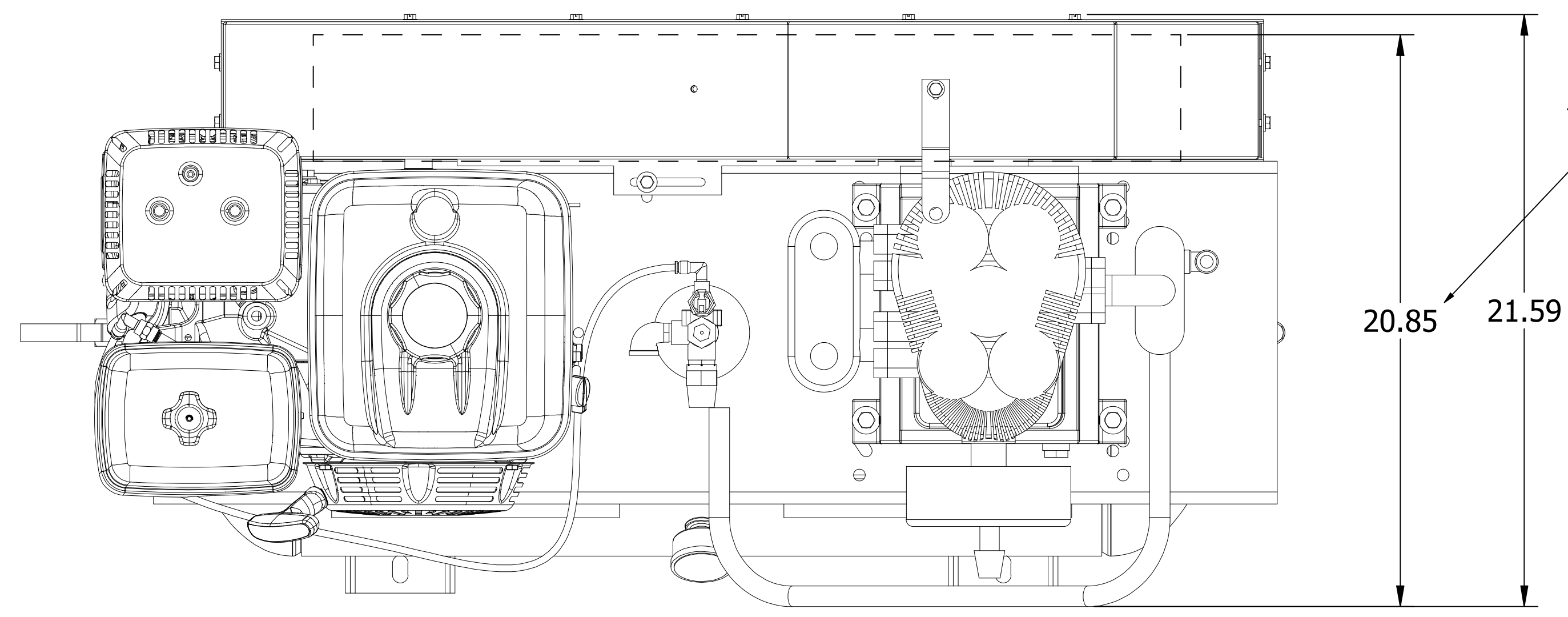
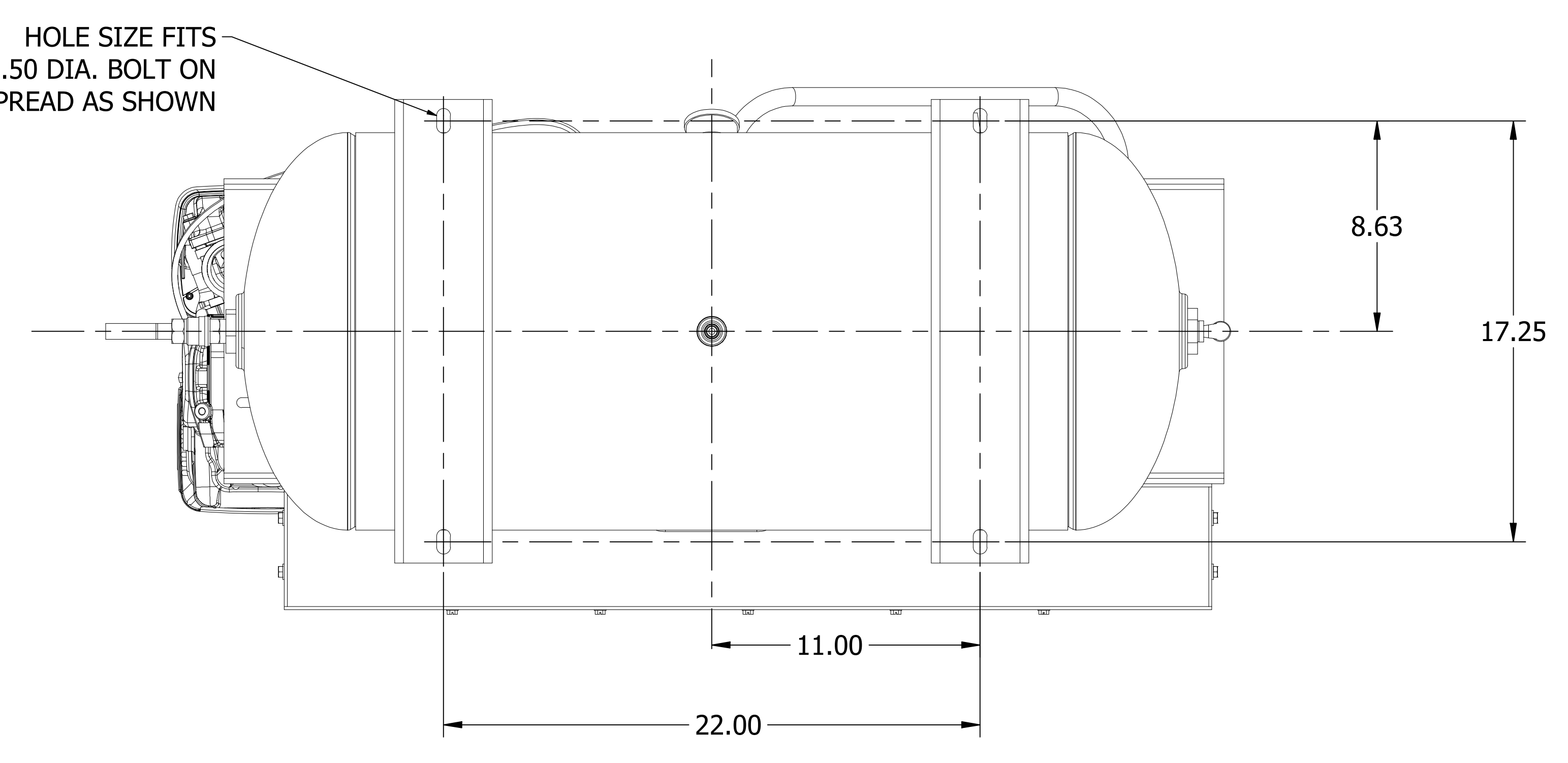

NOTES:
 1) ALL DIMENSIONS GIVEN IN INCHES.
 2) ALLOW A MINIMUM OF 12 INCHES ON ALL SIDES FOR SERVICE AND COOLING.
 3) DIMENSION OF ALTERNATE BELT GUARD DEPICTED.

Name: DWG.DIM.C1.30H.13HG		Part Number: 2022035582	
Material: Not Applicable		Internal: INV	
Finish: Not Applicable		Drawing Date: 11/30/2021	
Scale: 1:4	Family: UTYBALKER	Make From: UTY	Replaces: UTY
Version: DWG	Blank wt: 0.000	Fin wt: 0.000	Designation: UTY
Parent 3D model: 2022035582	Ed. Version 3D: For Approval	Disc checked: []	Prod checked: []
Date: 11/30/2021		Sheet: 1 / 1	
2022035582		2022035583	