

Ed.	Rev.	Description	Date	Int./Appd.
00.02		SEE REVISION 01 NOTES	09/22	JW

- REVISION 01 NOTES:
- NOTE REGARDING APPEARANCE OF BELT GUARD WAS ADDED.
 - NAME CHANGED TO ONLY REFLECT TANK SIZE AND PUMP.
 - DIMENSIONAL REPRESENTATION OF AFTERCOOLER ADDED.
 - NOTE REGARDING OPTIONAL FEATURES ADDED.

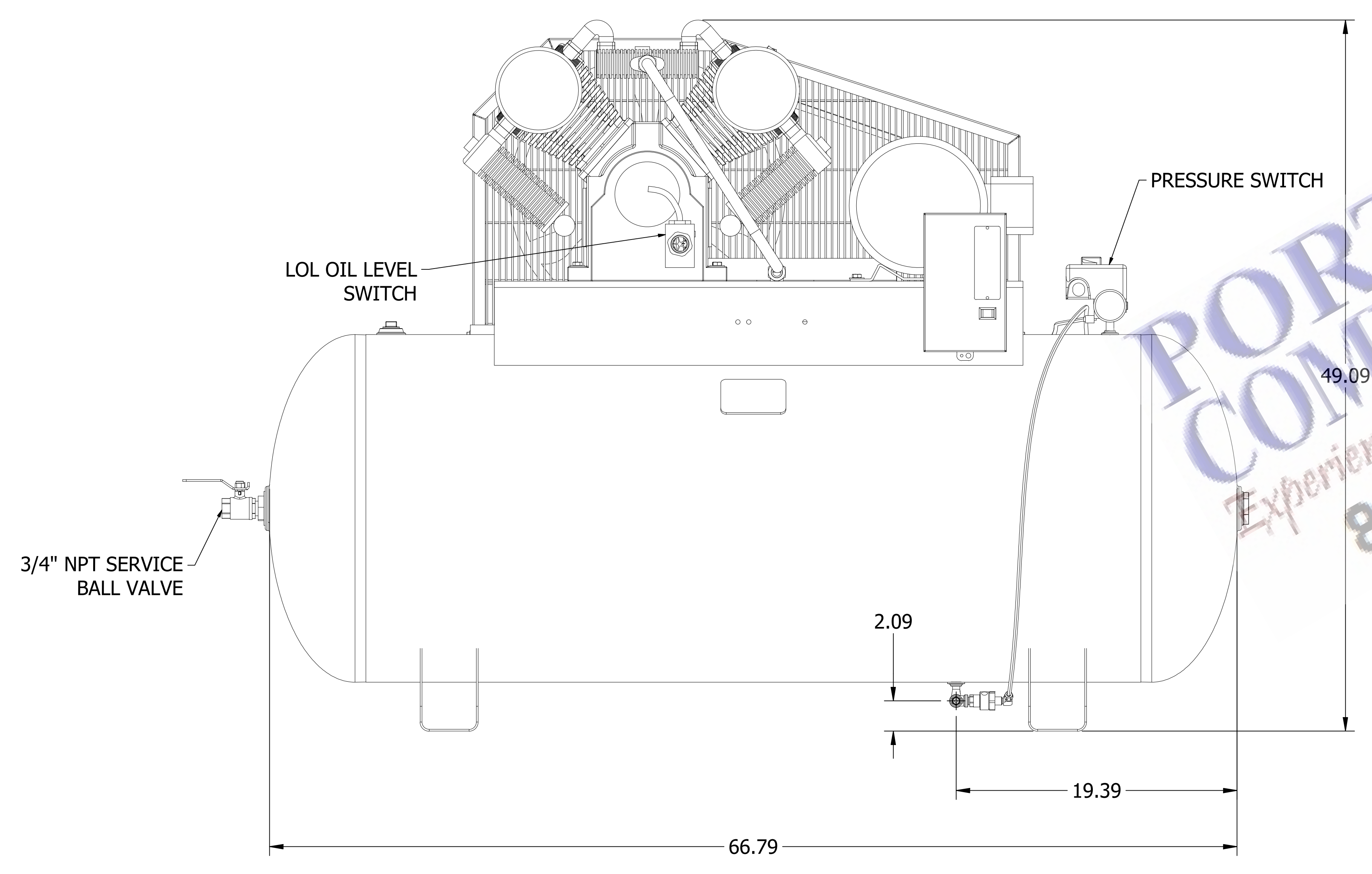
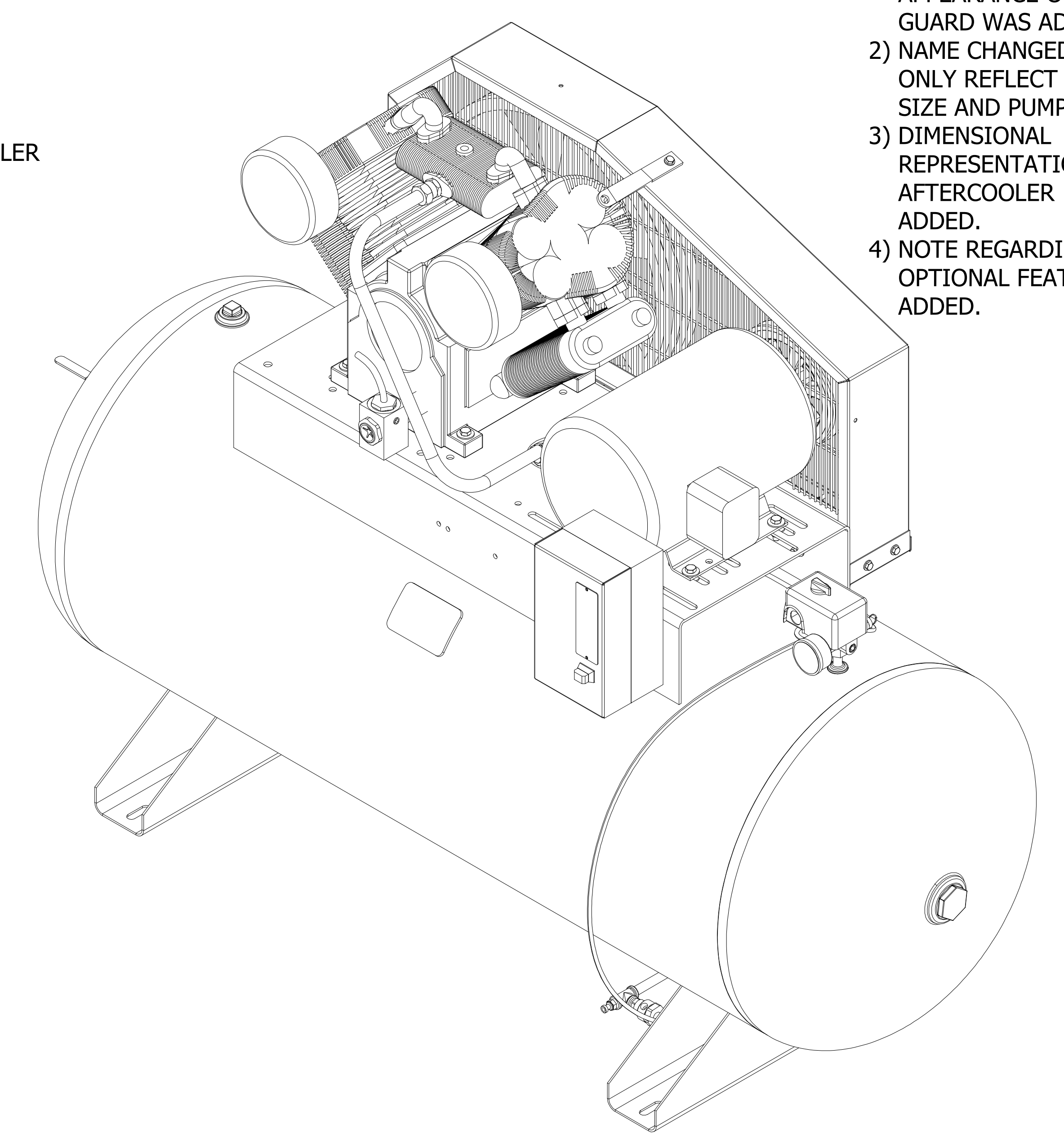
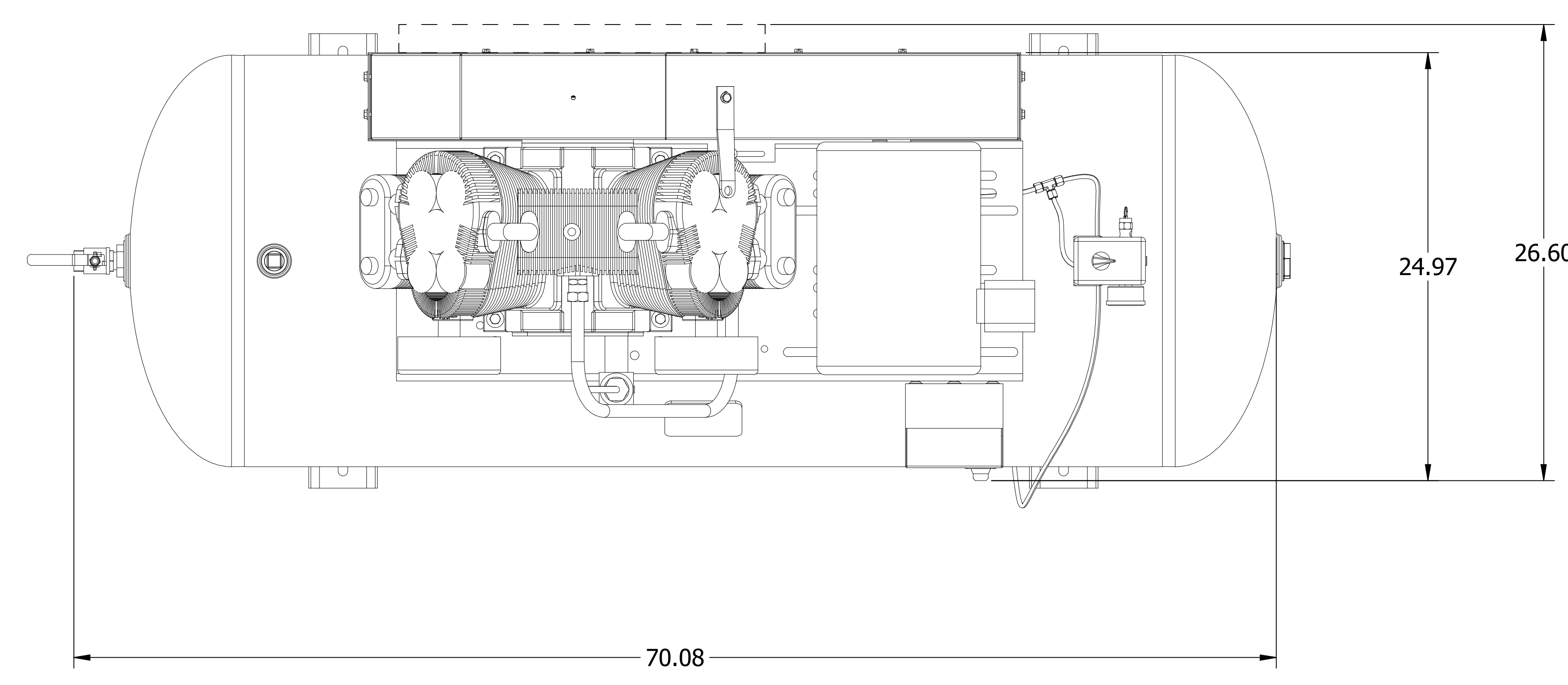

PORTLAND
COMPRESSOR

Experience You Can Depend On
800-542-8300

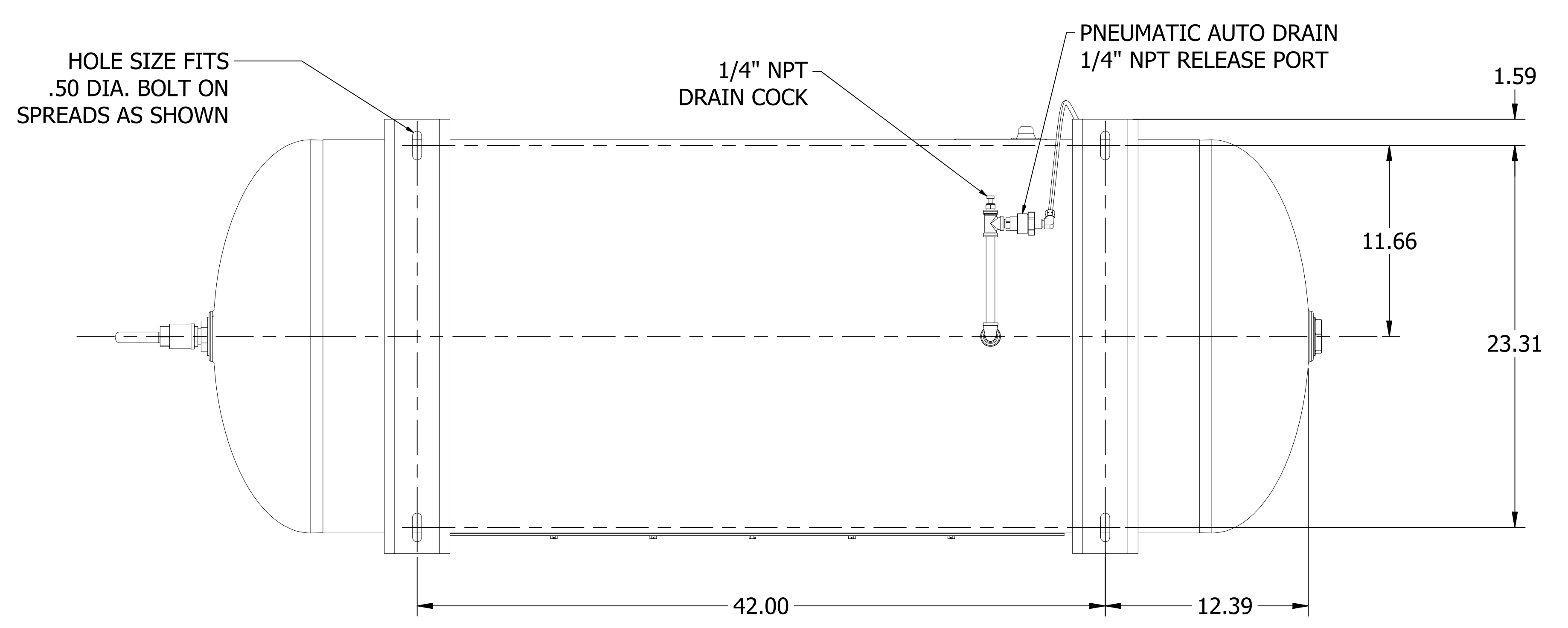
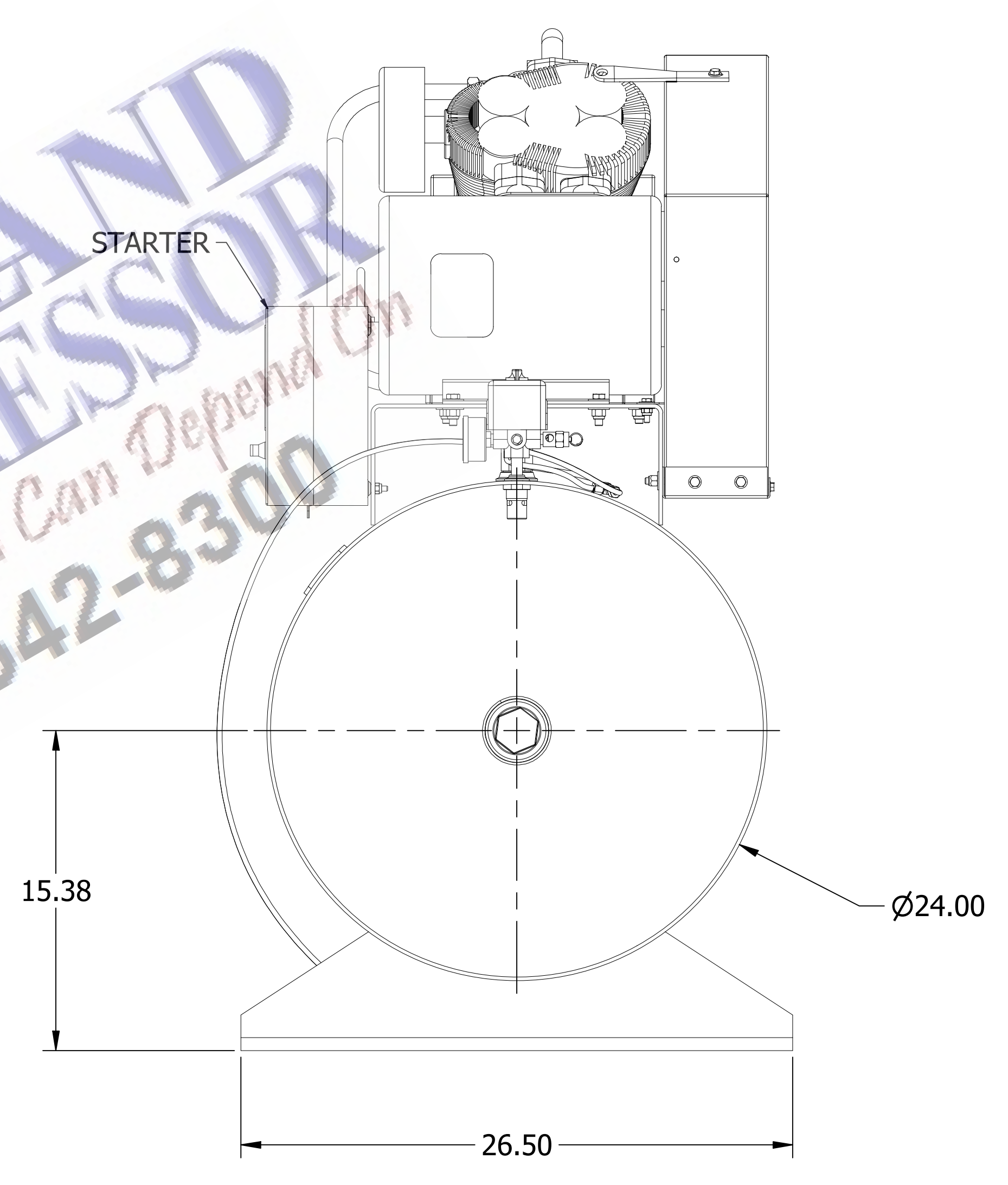

- NOTES:
- ALL DIMENSIONS GIVEN IN INCHES.
 - ALLOW A MINIMUM OF 12 INCHES ON ALL SIDES FOR SERVICE AND COOLING.
 - ACTUAL BELT GUARD MAY APPEAR DIFFERENT THAN WHAT IS SHOWN ABOVE
 - OPTIONAL ACCESSORIES ARE SHOWN. UNIT MAY NOT INCLUDE FEATURES DEPICTED.

<p>CONFIDENTIAL</p> <p>Copyright © 2021 UTY Walker LLC. All rights reserved. This drawing is the property of UTY Walker LLC. It is to be used only for the purpose intended. No part of this drawing may be reproduced without the written permission of UTY Walker LLC.</p>		<p>Name: DWG_DIM.C2_120H</p> <p>Material: Not Applicable</p> <p>Finish: Not Applicable</p>		<p>Scale: 1:5</p> <p>Drawn by: UTYWALKER</p> <p>2022035562</p>		<p>Family: Make From</p> <p>Version Dwg: Blank wt</p> <p>Ed. Version 3D</p>		<p>Similar to: INV</p> <p>Replaces: UTY</p> <p>0.0 0.0</p> <p>11/29/2021</p>		<p>Sheet: 1 / 1</p> <p>2022035563</p>	
--	--	--	--	--	--	---	--	--	--	---------------------------------------	--