

Oilless Reciprocating Air Compressor Pumps

Please read and save these instructions. Read carefully before attempting to assemble, install, operate or maintain the product described. Protect yourself and others by observing all safety information. Failure to comply with instructions could result in personal injury and/or property damage! Retain instructions for future reference.

Description

GENERAL

Powerex utilizes cutting-edge compressor technology to provide the most advanced oilless reciprocating air compressor in the industry. The Powerex reciprocating compressor is available in single and two stage models. Continuously lubricated, sealed bearings provide oil-free compressed air and long compressor life. The onboard fan, finned flywheel and temperature reducing composite piston create lower operating temperatures.

DRY TYPE INLET FILTER

The inlet filter on the oilless compressor assures 99% of particulate free air, down to 10 micron, is admitted to the unit. Change every 2500 hours or more often in dirty locations (See Figure 5).

PISTON AND PISTON RINGS

The Powerex oilless reciprocating compressor pistons are made of a high-strength, self-lubricating composite using the most advanced technology available. These heat reducing pistons eliminate the effect of excessive grease leakage at the wrist pin bearing. PTFE rings reduce wear and provide self lubrication. Piston rings should be replaced every 10,000 hours of operation (See Figure 12).

BEARING REGREASE

The wrist pin bearings of the OPS and OPT oilless compressors are needle bearings protected by two outer lip seals. This needle bearing becomes impacted and requires regreasing at 5,000 hours (See Figure 15).

BEARING SEALS

The wrist pin bearing lip seals prevent the lubricating grease from leaking from the bearing area. The two lip seals on each connecting rod require replacement every 10,000 hours (See Figure 16-22 or page 9).

Safety Guidelines

This manual contains information that is very important to know and understand. This information is provided for SAFETY and to PREVENT

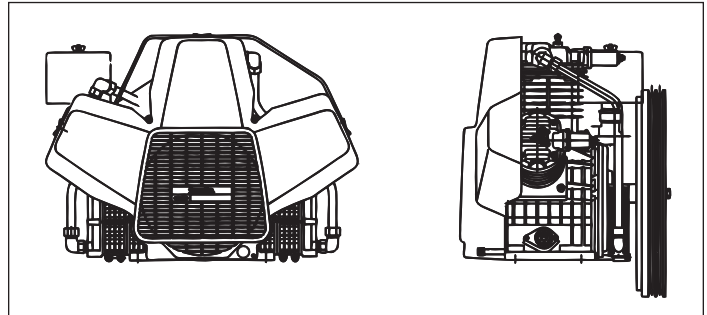

Specifications (Series)

Product	OPS / OPT Series Powerex Air Compressor Pumps	
Performance Specifications	See Page 2	
Lubrication	Grease-filled Bearing	
Pressure Settings	Cut-In: 90 psig	Cut-Out: 120 psig
	Cut-In: 125 psig	Cut-Out: 145 psig (High Pressure Unit)

Specifications (Performance)

Model	HP	Max. PSIG	SCFM @ 100 PSIG	RPM	No. of Cyl.	Bore	Stroke	Flywheel O.D.	Drive
OPS010	1 1.5	145	3.6 5.3	625 885	1	2.56	2.56	11.2	1 GR-A
OPS030	2 3	145	7.6 10.1	845 1115	2	2.56	2.36	13.8	1 GR-B
OPT050	5	145	16.5	800	2	(1) 4.13 x (1) 2.95	3.35	16.9	2 GR-B
OPT100	7.5 10	145	27.5 35.0	855 1090	3	(2) 3.54 x (1) 2.95	3.35	18.3	2 GR-B
OPT150	15	145	47.0	1140	3	(2) 4.13 x (1) 2.95	3.35	19.6	2 GR-B

EQUIPMENT PROBLEMS. To help recognize this information, observe the following symbols.

⚠ DANGER *Danger indicates an imminently hazardous situation which, if not avoided, WILL result in death or serious injury.*

⚠ WARNING *Warning indicates a potentially hazardous situation which, if not avoided, COULD result in death or serious injury.*

⚠ CAUTION *Caution indicates a potentially minor or moderate injury.*

NOTICE *Notice indicates important information, that if not followed, may cause damage to equipment.*

Installation

INSTALLATION SITE

⚠ DANGER

Breathable Air Warning

This compressor/pump is NOT equipped and should NOT be used "as is" to supply breathing quality air. For any application of air for human consumption, you must fit the air compressor/pump with suitable in-line safety and alarm equipment. This additional equipment is necessary to properly filter and purify the air to meet minimal specifications for Grade D breathing as described in Compressed Gas Association Commodity Specification G 7.1 - 1966, OSHA 29 CFR 1910. 134, ANSI and/or Canadian Standards Associations (CSA).

DISCLAIMER OF WARRANTIES

IN THE EVENT THE COMPRESSOR IS USED FOR THE PURPOSE OF BREATHING AIR APPLICATION AND PROPER IN-LINE SAFETY AND ALARM EQUIPMENT IS NOT SIMULTANEOUSLY USED, EXISTING WARRANTIES ARE VOIDED, AND POWEREX DISCLAIMS ANY LIABILITY WHATSOEVER FOR ANY LOSS, PERSONAL INJURY OR DAMAGE.



- The oilless compressor must be located in a clean, well lit and well ventilated area.
- The area should be free of excessive dust, toxic or flammable gases and moisture.
- Never install the compressor where the ambient temperature is higher than 105°F or where humidity is high.
- Clearance must allow for safe, effective inspection and maintenance.
- If necessary, use metal shims or leveling pads to level the compressor. Never use wood to shim the compressor.

VENTILATION

- If the oilless compressor is located in a totally enclosed room, an exhaust fan with access to outside air must be installed.

	Minimum Clearances
Above	24 inches
Drive belt side	12 inches
Other side	20 inches

- Never restrict the cooling fan exhaust air.
- Never locate the compressor where hot exhaust air from other heat generating units may be pulled into the unit.

WIRING

Refer to the general safety guidelines manual. All electrical hook-ups must be performed by a qualified electrician. Installations must be in accordance with local and national electrical codes.

Use solderless terminals to connect the electric power source.

Installation (Continued)

PIPING

Refer to the general safety guidelines manual.

1. Make sure the piping is lined up without being strained or twisted when assembling the piping for the compressor.
 2. Appropriate expansion loops or bends should be installed at the compressor to avoid stresses caused by changes in hot and cold conditions.
 3. Piping supports should be anchored separately from the compressor to reduce noise and vibration.
 4. Never use any piping smaller than the compressor connection.
 5. Use flexible hose to connect the outlet of the compressor to the piping so that the vibration of the compressor does not transfer to the piping. Make sure the flexible hose is rated for proper pressure and temperature before installing.
2. Be sure all pressure connections are tight.
 3. Check to be certain all safety relief valves, etc., are correctly installed.
 4. Make sure the inlet filter is properly installed.
 5. Visually check the rotation of the compressor pump. If the rotation is incorrect, have a qualified electrician correct the motor wiring.

SAFETY VALVES

A safety valve must be installed in the manifold or tank where the compressor pump is installed. The flow capacity of the safety valve must be equal to or greater than the capacity of the compressor.

1. The pressure setting of the safety valve must be no higher than the maximum working pressure of the tank.
2. Safety valves should be placed ahead of any possible blockage point in the system, i.e. shutoff valve.
3. Avoid connecting the safety valve with any tubing or piping.
4. Manually operate the safety valve every six months to avoid sticking or freezing.
5. The safety valve must be ASME approved.

HOURLY METER

The hourmeter on the oilless compressor indicates the actual number of hours the unit has been in operation. The hourmeter is also used to determine maintenance and service timing. **An hourmeter must be installed with every oilless compressor.**

CONDENSATE DRAIN VALVE

A condensate drain valve must be installed on any tank to allow removal of the liquid which will collect during compressor operation.

NOTICE *Drain liquid from tank daily.*

Operation

Powerex oilless compressors operate at a standard pressure of 120 PSIG. Two stage compressors operate at a maximum of 145 PSIG and are equipped for continuous run operation. Compressor RPM's are established by Powerex based on horsepower and operating pressure.

BEFORE START UP

1. Make sure all safety warnings, labels and instructions have been read and understood before continuing.

START-UP AND OPERATION

1. Follow all the procedures under "Before start-up" before attempting operation of the compressor.
2. Switch the electric source breaker on.
3. Open the tank discharge valve completely.
4. Check that the compressor operates without excessive vibration, unusual noises or leaks.
5. Close the discharge valve completely.
6. Check the discharge pressure. Also make sure the air pressure rises to the designated pressure setting by checking the discharge pressure gauge.
7. Check the operation of the pressure switch or the pilot valve for continuous run units by opening the stop valve and confirming the compressor starts or reloads as pressure drops.

Switch the breaker off if the compressor is not to be used for a long period of time.

5000 Hours - Valve Inspection/ Replacement

WARNING *Per OSHA regulations, ALL power must be locked out before performing any maintenance.*

INSPECT VALVE SET

1. Remove head bolts from cylinder head.
2. Remove cylinder head and valve set. If it is difficult to remove

Maintenance Schedule

Item	Action needed	Operating Hours									Remarks	
		500	2500	5000	7500	10,000	12,500	15,000	17,500	20,000		
Tank	Drain moisture	Daily										Drain tank daily
Inlet Air Filter	Inspect, Replace	●	▲	▲		▲		▲		▲		Every 2500 hours or less
Blower Fan	Clean			●		●		●		●		
Fan Duct	Clean			●		●		●		●		
Compressor Fins	Clean		▲	▲		▲		▲		▲		Every 2500 hours or less
Bearings - HP Wrist Pin	Inspect, Replace Pin, Regrease		▲	▲		▲		▲		▲		Every 2500 hours
Compression Rings	Inspect, Replace			▲		▲		▲		▲		Every 2500 hours
Bearings - LP Wrist Pin	Regrease	Note 4	▲	▲		▲		▲		▲		Every 2500 hours
Piston Set	Replace					▲				▲		
Cylinder	Inspect, Replace			●		●		●		●		
Unloader Set	Inspect, Replace			●		▲		●		▲		
Gasket Set	Replace					▲				▲		
Bearing Seal Wrist Pin	Replace					▲						
V-belt	Inspect, Replace	Note 3	●	▲		▲		▲		▲		

- Inspect
- ▲ Replace or perform action

Notes:

1. Inspect and perform maintenance periodically according to maintenance schedule.
2. The maintenance schedule relates to the normal operating conditions. If the circumstances and load condition are adverse, shorten the cycle time and do maintenance accordingly.
3. The tension of the V-belt should be adjusted during the initial stage (500H) and inspected every 2,500 hours afterwards. Proper belt tension for 1 to 3 HP units is 2-3 lbs./ .5 inch deflection; for 5 to 15 HP units, 4-6 lbs./ .5 inch deflection.
4. See page 8.

2500 Hours - Air Filter Element Replacement

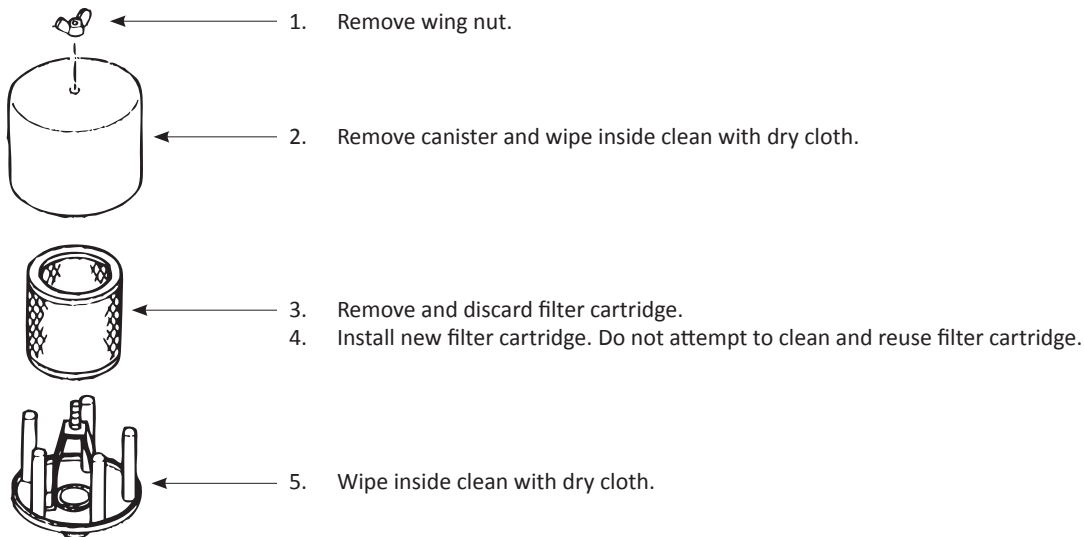

Figure 5 - Air Filter Replacement

by hand, insert screwdriver between cylinder and valve set and remove (See Figure 6 and 7).

INSPECTION AND MAINTENANCE

1. Check if exhaust valve (A) sticks to seat or is damaged (See Figure 8).
2. Check if there is breakage, gouge or damage to appearance of intake valve (B).
3. Lift intake valve 10 mm (3/8 inch) and check if there is peeling and/or wear on coating surface of valve set (C).

- CAUTION** *Lifting intake valve too much can cause damage to intake valve.*
4. Replace intake valve set if valve plate or valves are worn or wear is over 0.5 mm (0.020 inches) in depth.
If exhaust valve rises upwards, clean seat surface of foreign matter.
 5. Clean the whole valve set taking care not to damage seat surface and remove dust.
 6. If viton seals (upper and lower) reach inspection time, replace them. Even if its not time to inspect, be sure to replace if they do not protrude from groove or seal has hardened or been damaged.
 7. Be sure to replace plastic seat in cylinder (See Figure 10).
 8. Install valve set while paying attention to black plastic seat of intake valve installed in cylinder (so that you do not drop port or insert tip of valve under seat).
 9. Install cylinder head and tighten head bolts with designated torque.

NOTES:

- When using valve set again, replace upper and lower viton seals.
- When replacing valve set, replace with upper and lower viton seals (valve set with packing set). You cannot reuse disassembled valve set.

We are not responsible for any problems caused by reuse of disassembled valve set.

REASSEMBLY

Assemble in reverse order of disassembling. Tighten each section with designated tightening torque (See Chart on page 6).

Cylinder Inspection / Replacement

WARNING *Per OSHA regulations, ALL power must be locked out before performing any maintenance.*

INSPECTION / REPLACEMENT

1. Remove cylinder head and valve set. Pay attention not to lose semicircular (black plastic) seat inserted at top surface of cylinder (see Figure 9).
2. Remove cylinder bolts and pull off cylinder slowly. Make sure piston does not drop down and get damaged. Note cylinder orientation.
3. Inspect cylinder surface. If treated area is worn and metal is exposed, replace. If there are several vertical scratches at a narrow



Figure 6

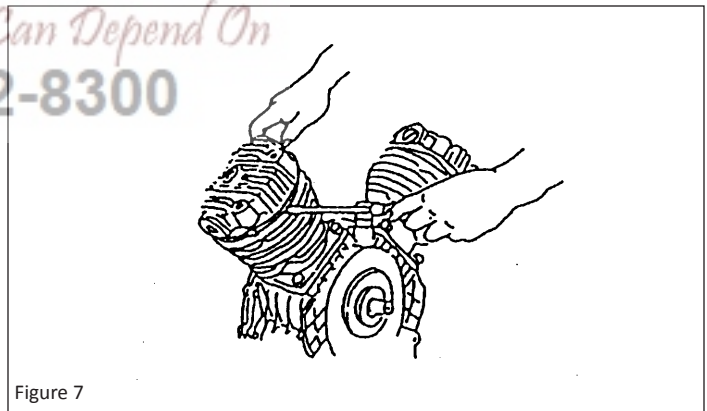

Figure 7

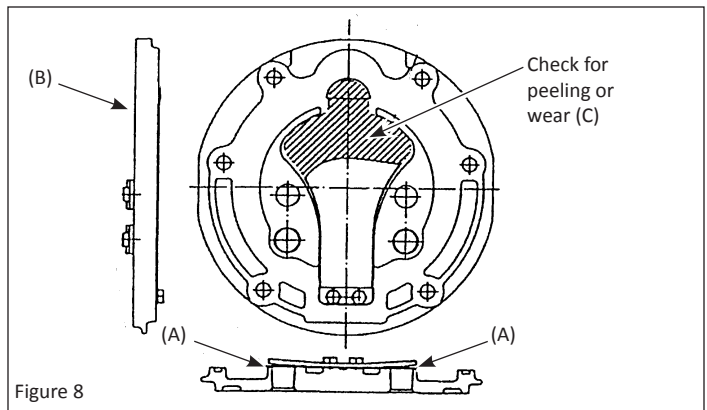

Figure 8

Oilless Reciprocating Air Compressor Pumps

distance, replace (see Figure 10).

NOTE: Blackish streaks you can feel with your nail or finger are not damage but sliding marks of piston and piston ring. You do not need to replace the piston set or cylinder even if there are several marks on the whole diameter of the cylinder.

REASSEMBLY

1. Assemble in reverse order of disassembling cylinder.
2. Direction of cylinder is set so that semicircular spot facing, to which seat (black plastic) is inserted, faces toward flywheel side.
3. Tighten cylinder bolts with designated torque (refer to chart below).

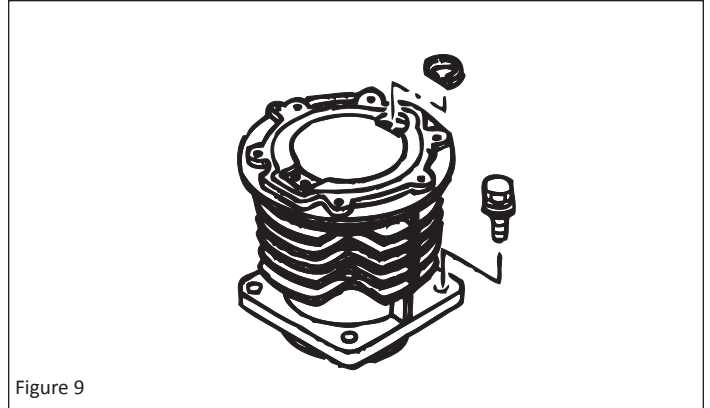

Figure 9



Figure 10

Model	Cylinder Bolt Torque	Head Bolt Torque
OPS010 / OPS030	156 in. lb.	156 in. lb.
OPT050 / OPT100 / OPT150	295 in. lb.	156 in. lb.

10,000 Hours - Piston Ring Replacement

⚠WARNING

Per OSHA regulations, ALL power must be locked out before performing any maintenance.

INSPECTION / REPLACEMENT

1. Remove cylinder head tubing and cylinder bolts.
2. Pull cylinder and head assembly off slowly. Do not allow piston to drop out of cylinder and get damaged.
3. Remove piston rings. Do not use ring tool to remove ring. Expand by hand only wide enough to remove from piston. Note orientation of each for proper replacement.

NOTE: Expanding ring too much and deforming can cause wear and leakage. (See Figure 12). Mark upper surface (not lower surface) of removed ring for easy distinction.

4. Inspect lower surface (A) and outer side surface (B) of ring (See Figure 13). Measure thickness (C) of ring with calipers. Replace if foreign matter enters (A, B) or deep damage is found or (C) dimension is less than 2.5 mm (0.10 inches) at any point around the rings circumference.

NOTE: Clean the whole ring and ring groove with soft clean cloth.

⚠CAUTION

Ring and piston dust build up in the ring groove can cause knocking.

This is sometimes mistaken for bad valve or bearing.

REASSEMBLE: Pay attention to the fit of the piston and wrist pin fit. There should be no axial play or looseness in the wrist pin area.

NOTE: Do not separate piston from connecting rod when inspecting piston or ring. If you remove piston from connecting rod, you may damage oil seal of connecting rod and needle bearing.

PISTON INSPECTION/REPLACEMENT

1. Inspect for appearance; if there is deep damage or crack on top of piston or at pin boss, replace piston.
2. Remove piston ring and inspect for breakage or droop of ring land; if damage is found, replace piston.
3. Remove o-rings on both sides of wrist pin. Push wrist pin to one side

NOTE: Install bearing retention sleeve in grease kit/piston set. The retention sleeve is to prevent the needle bearing from falling out of the bearing area. On the HP cylinder only.

4. Remove wrist pin; remove piston.
5. Install o-ring in flywheel side of new piston (see Page 8).
6. Install piston onto con rod. Slide wrist pin into place. Install second o-ring. Make sure piston is in proper direction (see Page 8).
7. Install rings in proper grooves (for inspection) and proper gap orientation.

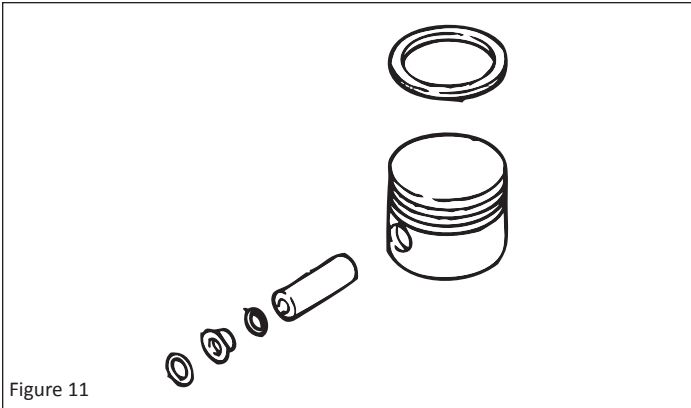

Figure 11

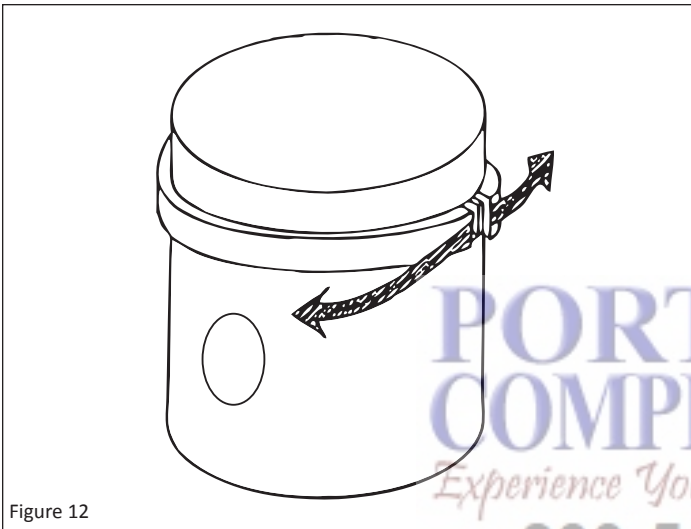

Figure 12

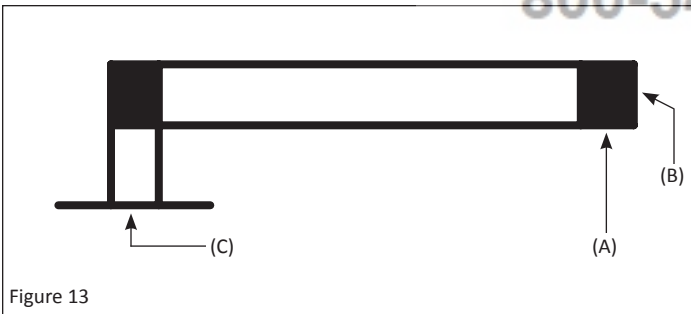

Figure 13

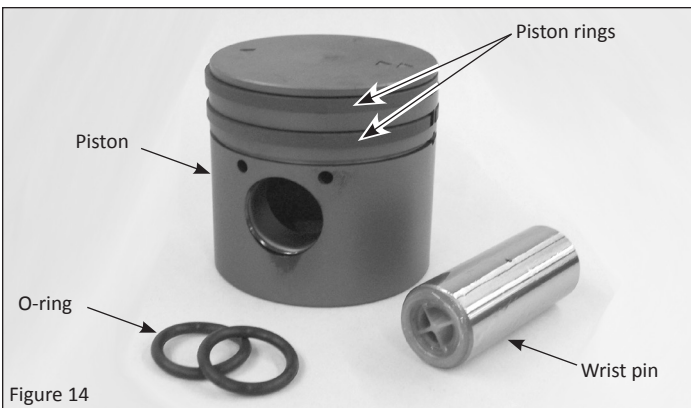

Figure 14









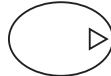

10,000 Hours - Piston Ring Replacement (Continued)

WRIST PIN BEARING REGREASE

1. Remove cylinder/head assembly and piston.
2. For low pressure wrist pin bearings, fill needle area with IP634500AJ Powerex approved grease.

3. For high pressure wrist pin bearings, replace wrist pin (#91924680). (OPT Pumps Only)
4. Replace cylinder/head assembly and piston as in procedures above.
5. Tighten all fittings and bolts to designated torques.

Piston Orientation Chart for Oilless OPS / OPT Series

Pump Compressor Model	Bore	No. Cylinders	No. of Piston Rings per Piston	Mark on Top of Piston
OPS010	65 mm	1	1	<p>Flywheel side</p>  <p>Fan Side</p>
OPS030	65 mm	1	1	<p>Flywheel side</p>  <p>Fan Side</p> 
OPT050	LP 105 mm	1	1	<p>Flywheel side</p>  <p>Fan Side</p> 
	HP 75 mm	1	2	
OPT100	LP 90 mm	2	1	<p>Flywheel side</p>  <p>Fan Side</p>  
	HP 75 mm	1	2	
OPT150	LP 105 mm	2	1	<p>Flywheel side</p>  <p>Fan Side</p>  
	HP 75 mm	1	2	

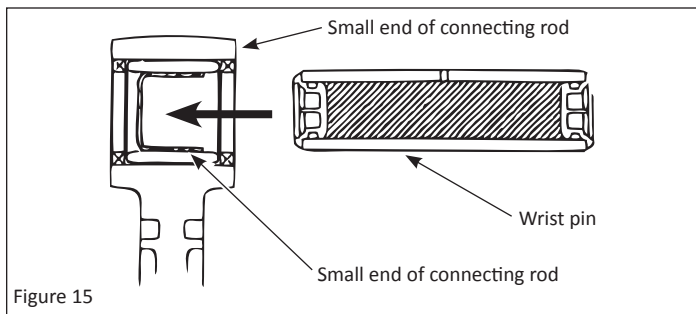

NOTE: The orientation in which the pistons are reinstalled is very important. Improper placement will cause premature wear of the ring and piston.

NOTE: When removing HP piston on two-stage pumps, remove piston and then insert retention sleeve having the same diameter of wrist pin or piston to small end of connecting rod. If not, you may drop or lose needles from the bearing, as HP needle bearing does not have support.

CAUTION Fit piston by referring the marking on the top of the piston surface and list on above chart.

NOTE: Gradually insert wrist pin while turning it. Inserting with force can damage oil seal of needle bearing.

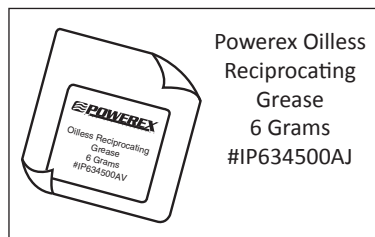

*** FOR LOW PRESSURE WRIST PIN BEARINGS ONLY**

Wrist Pin Bearing Seal Replacement (Replace Every 10,000 Hours)

REPLACING OIL SEAL

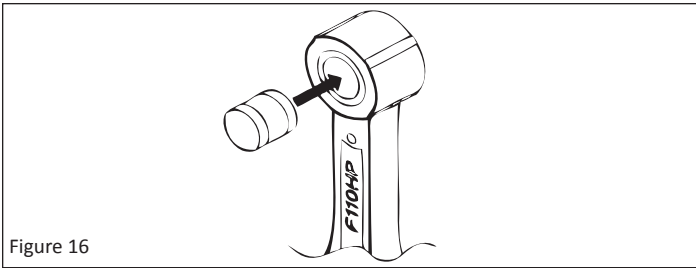

Figure 16

1. Insert the plastic retention sleeve which protects the needle bearing from dropping out.

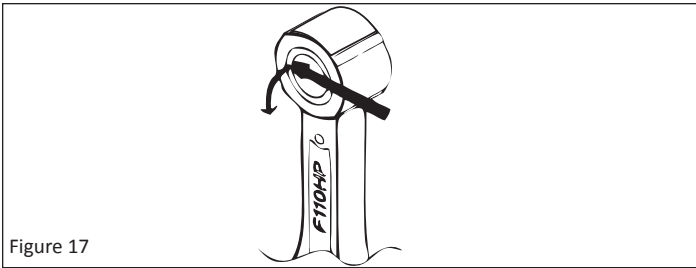

Figure 17

2. Remove the two oil seals by using a screwdriver.

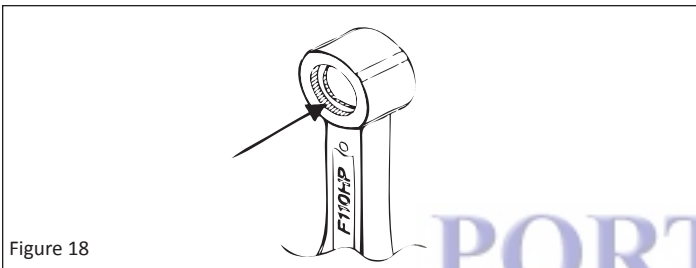

Figure 18

3. Clean both surfaces where oil seals are removed.

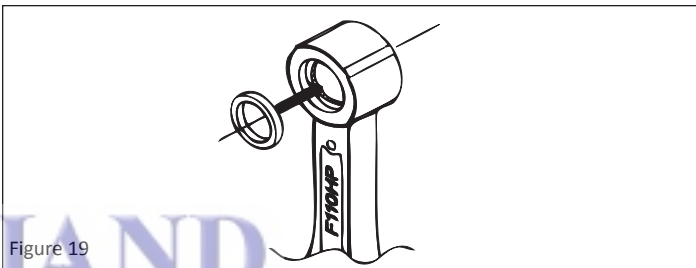

Figure 19

4. Push the oil seal into the small bearing end horizontally.

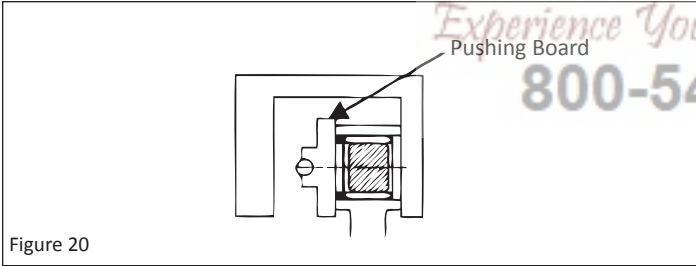

Figure 20

5. Press the oil seal with a C-clamp into the small bearing end.
6. Repeat on opposite side.

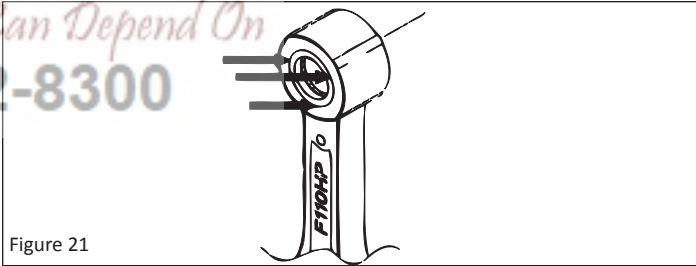

Figure 21

7. Apply a small volume of adhesive at several points.

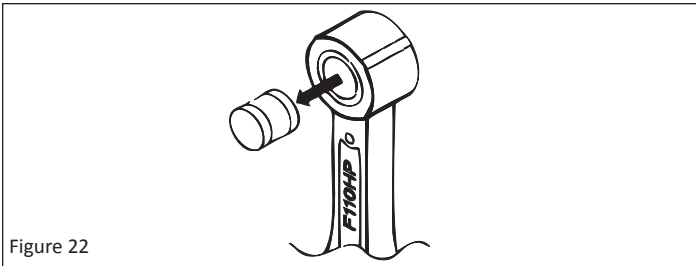

Figure 22

8. Remove the retention sleeve inserted at the first step.

NOTE: You may use a "C" clamp or two large washers and bolt with nut through the bearing. Then apply pressure to install the seals. This makes it easy to replace the seals without removing the crankshaft.

20,000 Hours - Connecting Rod, Wrist Pin and Crankshaft

⚠ WARNING

Per OSHA regulations, ALL power must be locked out before

performing any maintenance.

REPLACE CONNECTING ROD SET AND CRANKSHAFT AS A SET

Pressing bearing into connecting rod and connecting rod set into crankshaft requires special fixtures. Without such fixtures, the squareness and parallelism of each part will be affected.

REMOVE CYLINDER/HEAD ASSEMBLY AND PISTONS IN THIS ORDER

1. Bearing at large end of connecting rod: Replace if it does not move or feels stuck holding and moving small end of connecting rod.
2. Bearing of crankshaft: Replace if you feel some resistance when slowly turning shaft.
3. Bearing at wrist pin: Check for breakage of needle bearing and damage of cage.

DISASSEMBLING: CRANKSHAFT SET

1. Remove cylinder/head, assemblies and pistons.
2. Remove bolts from bearing cap and remove bearing cap.
3. Lightly tap shaft fan side with non-shock hammer (avoid metal hammer) and remove crankshaft. After bearing leaves the crankcase bore, pull connecting rod out as illustrated and remove it from crankcase (See Figure 23).

REASSEMBLY

1. Heat bearing housing of crankcase with industrial dryer or simple burner just the same as disassembling.
2. Insert crankshaft set into crankcase in reverse order of disassembling and insert bearing into housing.
3. Tap shaft from pulley side with non-shock hammer and insert it inwards.
4. Fit bearing case. Grease bearing housing of bearing case.
5. Replace pistons and cylinder/head assemblies per the inspection procedure listed previously.

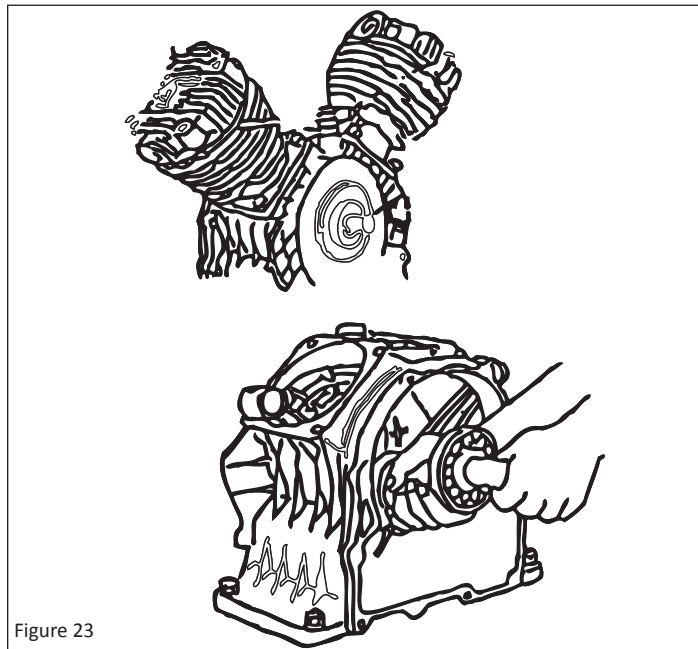

**PORTLAND
COMPRESSOR**
Experience You Can Depend On
800-542-8300

Oilless Reciprocating Air Compressor Pumps

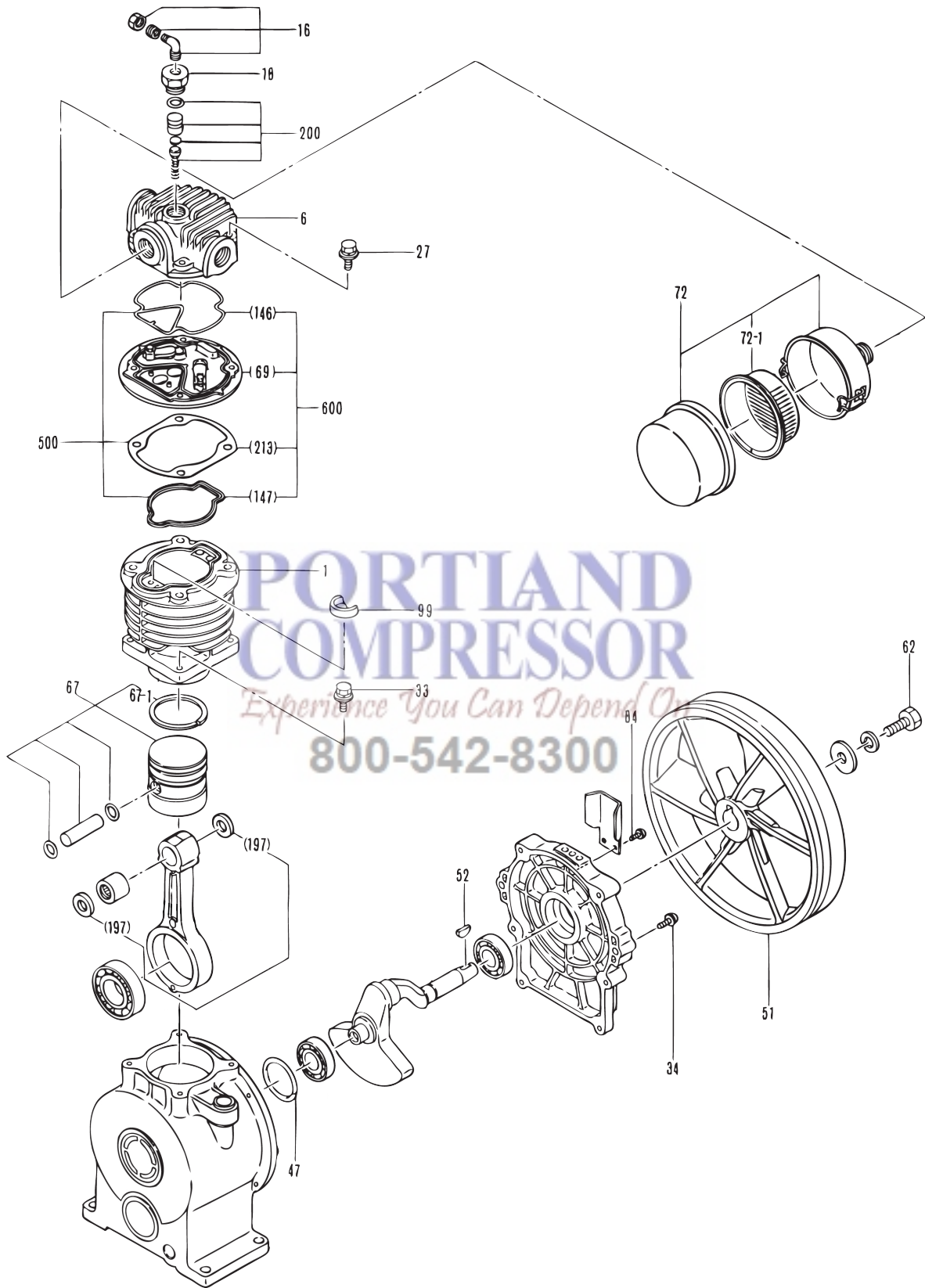

Figure 24 - Replacement Parts Illustration for OPS010

Oilless Reciprocating Air Compressor Pumps

Ref. No.	Description	Part Number for Model OPS010	Quantity
1	Cylinder	91000560	1
6	Cylinder head	91003630	1
16	Elbow (Unloader)	96800261	1
18	Unloader cap	91052041	1
27	Bolt (cylinder head)	96137835	4
33	Bolt (cylinder)	96137825	8
34	Bolt (bearing cap)	96137620	8
47	O-ring	91146550	1
51	Flywheel pulley	91201552	1
52	Parallel pin	91271550	1
62	Hex blot (fan, flywheel)	96992857	1
67	Piston set	91903640	1
67-1	Piston ring	91246640	1
72	Intake filter set	91906550	1
72-1	Intake filter	ST073923AV	1
84	Screw (dust cover)	96131508	2
99	Seat (intake valve)	91301560	1
197	Lip seals wrist pin	97190162	2
200	Unloader set	91931561	1
500	Gasket set	91936640	1
600	Valve set with gasket	91933640	1

**PORTLAND
COMPRESSOR**
Experience You Can Depend On
800-542-8300

Oilless Reciprocating Air Compressor Pumps

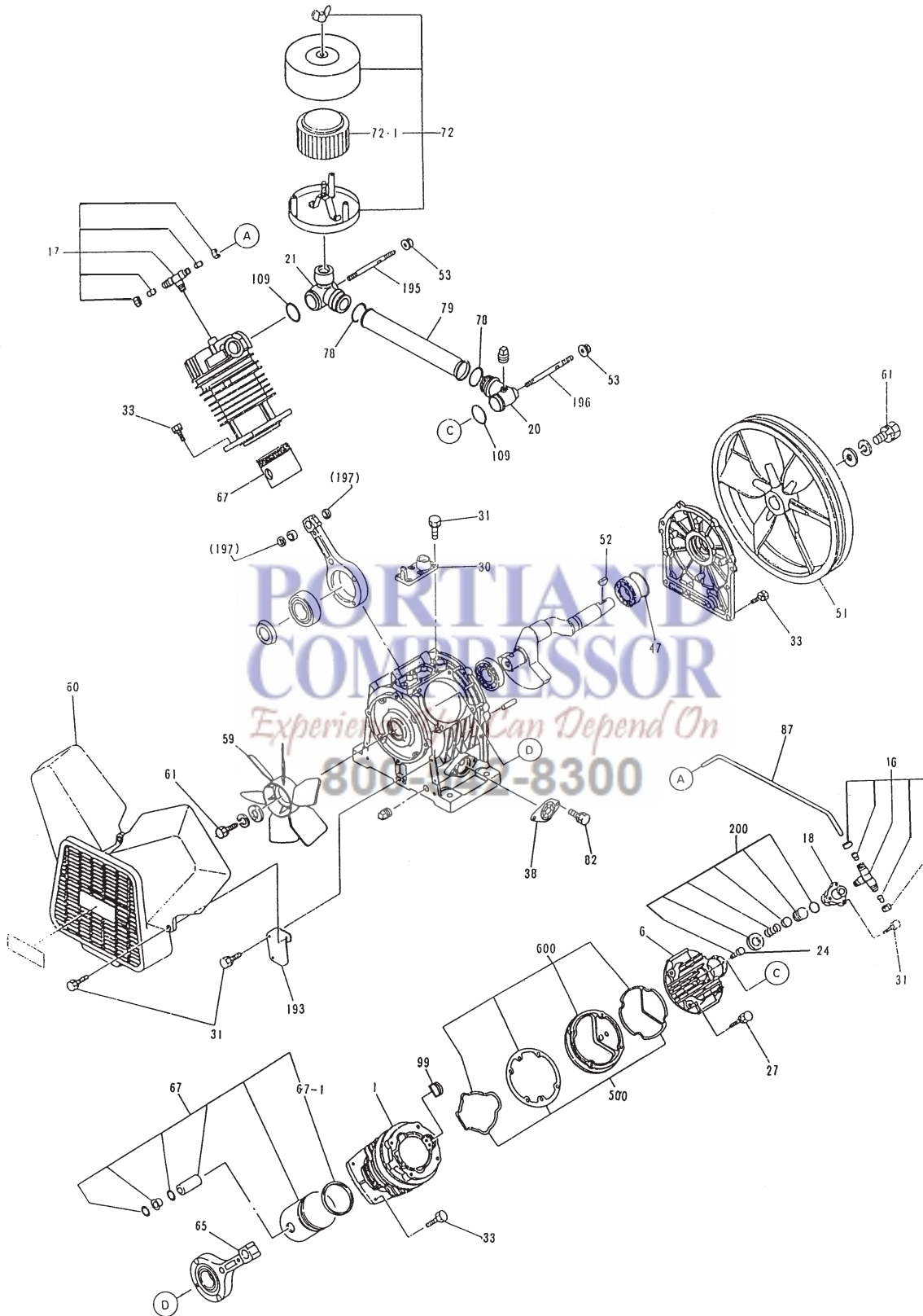

Figure 25 - Replacement Parts Illustration for OPS030

Oilless Reciprocating Air Compressor Pumps

Ref. No.	Description	Part Number for Model OPS030	Quantity
1	Cylinder	91000560	2
6	Cylinder head	91003640	2
16	Elbow (unloader)	96800261	1
17	Tee union assembly	96803261	1
20	Intake joint (1)	91345561	1
21	Intake joint (2)	91346571	1
24	Spring guide set	91932561	2
27	Bolt (cylinder head)	96137835	8
30	Flange (breather)	91176661	1
31	Bolt	96995831	20
33	Bolt (cylinder)	96137825	8
34	Bolt (bearing cap)	96137620	8
38	Filter (crank case)	91348690	1
47	O-ring	91146560	1
51	Flywheel pulley	91202560	1
52	Woodruff key	96600013	1
53	Hex nut	96994016	2
59	Fan	91220560	1
60	Cover (fan)	91134560	1
61	Hex bolt (fan, flywheel)	96992857	2
67	Piston set	91903640	2
67-1	Piston ring	91246640	2
72	Intake filter set	91907570	1
72-1	Intake filter	ST073905AV	1
78	O-ring	96630032	2
79	Intake pipe	91407560	1
82	Screw (filter)	96131508	2
87	Tube	91909400	1
99	Seat (intake valve)	91301560	2
109	O-ring (intake joint)	96639906	2
193	Fan guard	91135560	2
195	Bolt (intake joint 1)	91095570	1
196	Bolt (intake joint 2)	91095560	1
197	Lip seals wrist pin	97190162	4
200	Unloader set	91931561	2
500	Gasket set	91936640	2
600	Valve set with gasket	91933640	2

PORTLAND
COMPRESSOR
Experience You Can Depend On
800-542-8300

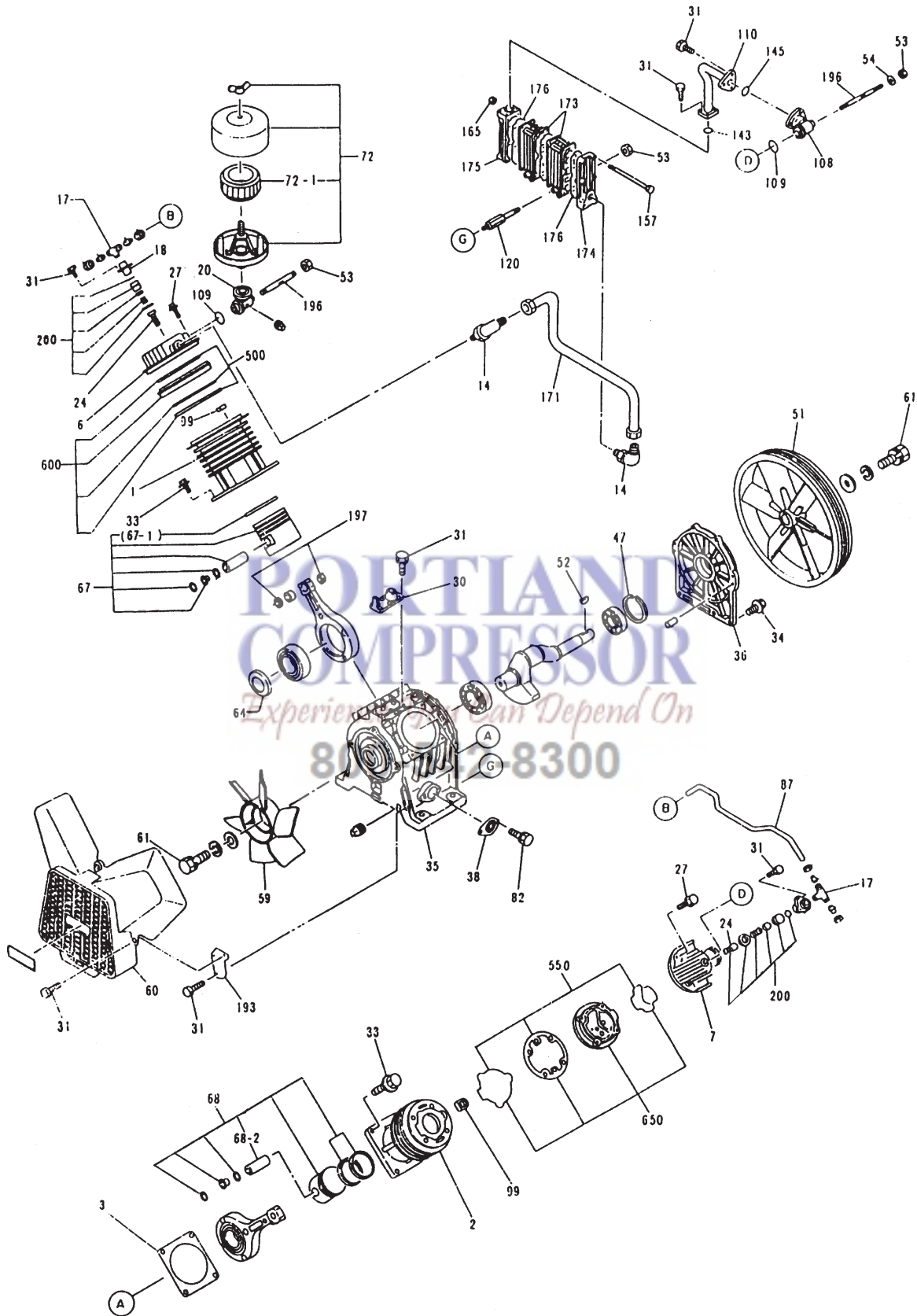

Figure 26 - Replacement Parts Illustration for OPT050

Oilless Reciprocating Air Compressor Pumps

Ref. No.	Description	Part Number for Model OPT050	Qty.	Ref. No.	Description	Part Number for Model OPT050	Qty.
1	Cylinder (LP)	91000680	1	82	Screw (Filter)	96235304	2
2	Cylinder (HP)	91947680	1	87	Unloader Tube	91420661	1
3	Liner	91177680	2	99	Seat (Intake Valve)	91301691	2
6	Cylinder Head (LP)	91004690	1	108	Intercooler Flange	91403690	1
7	Cylinder Head (HP)	91014680	1	109	O-ring (Intake joint)	96639906	2
14	Elbow (Intercooler)	91415690	2	110	Connecting Pipe	91400660	1
17	Tee Union Ass'y	96803261	2	120	Bolt (Intercooler)	91435692	2
18	Unloader Cap	91052451	2	143	O-Ring (Connecting Pipe)	96632825	1
20	Intake Joint	91345660	1	145	O-Ring (Connecting Pipe)	96632835	1
24	Spring Guide Set	91949694	2	157	Hex. Bolt (Intercooler)	96996460	6
27	Bolt (Cylinder Head)	96137850	10	165	Nut (Intercooler)	96994015	6
30	Flange (Breather)	91176661	1	171	Connecting Pipe Set	91955721	1
31	Bolt (Unloader Cap)	96995831	26	173	Intercooler	91404680	1
33	Bolt (Cylinder)	96137130	8	174	Intercooler Flange (1)	91405690	1
34	Bolt (Bearing Cap)	96137830	10	175	Intercooler Flange (2)	91406690	1
38	Filter (Crank Case)	91348690	1	176	Gasket (Intercooler)	91432690	2
47	O-ring	91146430	1	193	Fan Guard	91144660	2
51	Flywheel Pulley	91201660	1	196	Bolt (Intake Joint)	91344690	2
52	Woodruff Key	96600016	1	197	Lip seals wrist pin	97191000	4
53	Hex Nut	96994016	4	200	Unloader Set	91932682	2
54	Washer	96991512	1	500	Gasket Set (LP)	91936680	1
59	Fan	91220690	1	550	Gasket Set (HP)	91937681	1
60	Cover (Fan)	91134660	1	600	Valve Set with Gasket (LP)	91933681	1
61	Hex Bolt (Fan, Flywheel)	96992817	2	650	Valve Set with Gasket (HP)	91934683	1
67	Piston Set (LP)	91903680	1				
67-1	Piston Ring (LP)	91236681	1				
68	Piston Set (HP)	91910673	1				
68-1	Piston Ring (HP)	91930680	1				
68-2	Wrist Pin (Prepacked)	91924680	1				
72	Intake Filter Set	91907660	1				
72-1	Intake Filter	ST073905AV	1				

Oilless Reciprocating Air Compressor Pumps

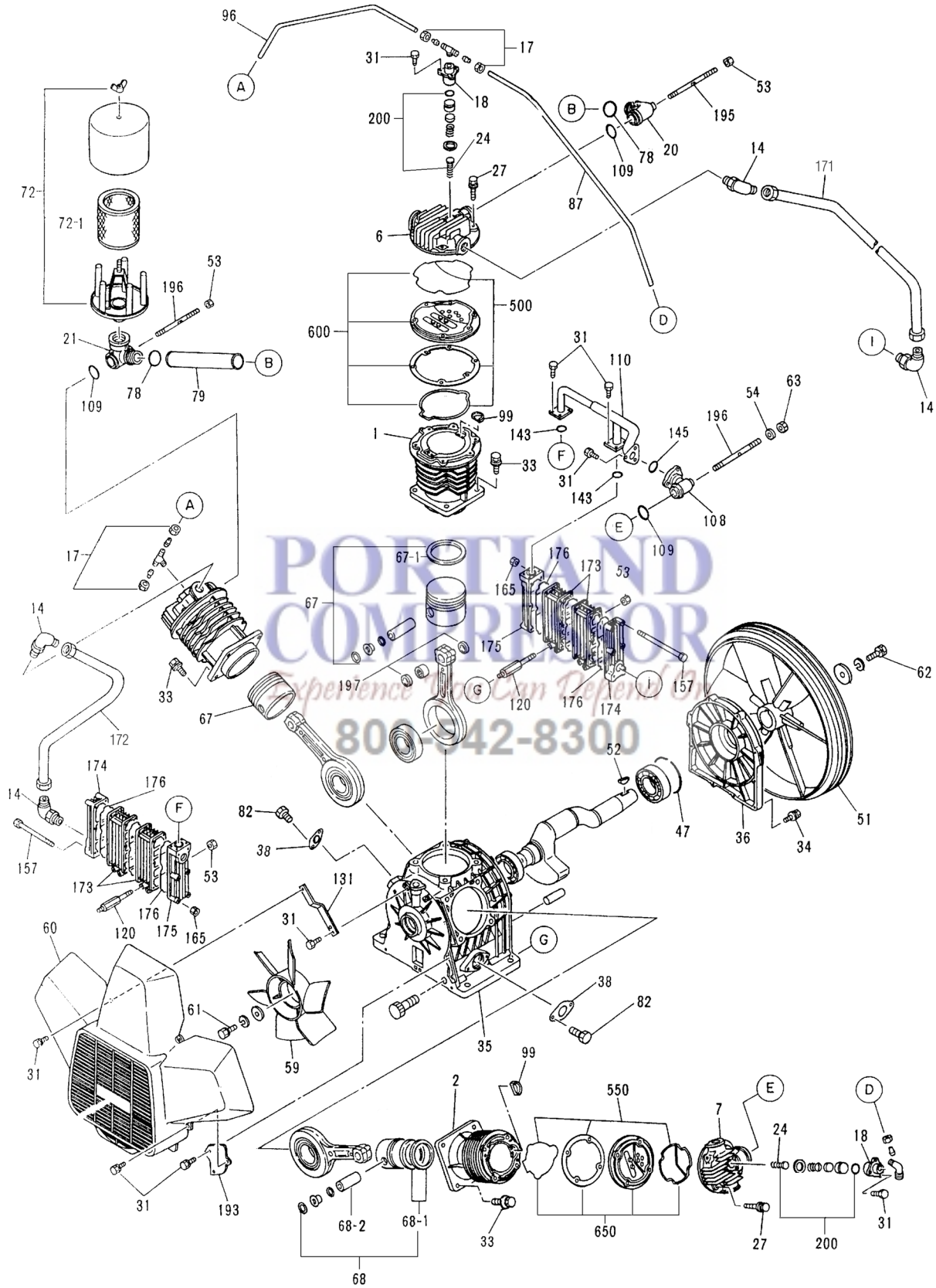

Figure 27 - Replacement Parts Illustration for OPT100 and OPT150

Oilless Reciprocating Air Compressor Pumps

Ref. No.	Description	Part Number for Model		Quantity
		OPT100	OPT150	
1	Cylinder (LP)	91000670	91000680	2
2	Cylinder (HP)	91947680	91947680	1
6	Cylinder head (LP)	91004670	91004690	2
7	Cylinder head (HP)	91014680	91014680	1
14	Elbow (Intercooler)	91415690	91415690	4
17	Tee union assembly	96803261	96803261	2
18	Unloader cap	91052451	91052451	3
20	Intake joint (1)	91345691	91345691	1
21	Intake joint (2)	91346690	91346690	1
24	Spring guide set	91949694	91949694	3
27	Bolt (Cylinder head)	96137850	96137850	16
31	Bolt (Unloader cap)	96995831	96995831	30
33	Bolt (Cylinder)	96137130	96137130	12
34	Bolt (Bearing cap)	96137830	96137830	10
38	Filter (Crank case)	91348690	91348690	1
47	O-ring (Bearing cap)	91146690	91146690	1
51	Flywheel pulley	91201590	91201690	1
52	Woodruff key	96600016	96600016	1
53	Hex nut	96994016	96994016	6
54	Washer (Intercooler)	96991512	96991512	1
59	Fan	91220690	91220690	1
60	Fan cover	91134690	91134690	1
61	Hexagon bolt (Fan)	96992817	96992817	1
62	Hexagon bolt (Flywheel)	96992833	96992833	1
63	Hexagon nut (Intake joint)	96382086	96382086	1
67	Piston set (LP)	91903670	91903680	2
67-1	Piston ring (LP)	91236671	91236681	2
68	Piston set (HP)	91910673	91910673	1
68-1	Piston rings (HP)	91930680	91930680	1
68-2	Wrist pin set (prepacked)	91924680	91924680	1
72	Intake filter set	91907590	91907690	1
72-1	Intake filter	ST073907AV	ST073907AV	1
78	O-ring (Intake pipe)	96630032	96630032	2
79	Inlet pipe	91407691	91407691	1
82	Bolt (Crankcase filter)	96131508	96131508	4
87	Unloader tube	91420690	91420690	1
96	Unloader tube	91419600	91419600	1
99	Wear pad, valve	91301691	91301691	3
108	Intercooler Joint	91403690	91403690	1
109	O-ring (Intercooler Joint)	96639906	96639906	3
110	Connecting Pipe	91402680	91402680	1
120	Bolt (Intercooler)	91435692	91435692	4
131	Cover Bracket	91413690	91413690	2
143	O-ring (Connecting Pipe)	96632825	96632825	2
145	O-ring (Connecting Pipe)	96632835	96632835	1
157	Hex bolt (Intercooler)	96996460	96996460	6
165	Nut (Intercooler)	96994015	96994015	6
171	Connecting Pipe Set (1)	91955780	91955890	1
172	Connecting Pipe Set (2)	91955790	91955900	1
173	Intercooler	91404680	91404680	2
174	Intercooler Flange (1)	91405690	91405690	2
175	Intercooler Flange (2)	91406690	91406690	2
176	Gasket (Intercooler)	91432690	91432690	4
193	Fan Guard	91135690	91135690	2
195	Bolt (Intake Joint 1)	91343690	91343690	1
196	Bolt (Intake Joint 2)	91344690	91344690	2
197	Lip seals wrist pin	97191000	97191000	6
200	Unloader Set	91932682	91932682	3
500	Gasket Set (LP)	91936670	91936680	2
550	Gasket Set (HP)	91937681	91937681	1
600	Valve Set with Gasket (LP)	91934691	91933681	2
650	Valve Set with Gasket (HP)	91934683	91934683	1

PORTLAND
COMPRESSOR

Experience You Can Depend On

800-542-XXXX

Notes

**PORTLAND
COMPRESSOR**
Experience You Can Depend On
800-542-8300

Powerex Limited Warranty – Applicable to Non-OEM Customers in the U.S. & Canada Only

Warranty and Remedies.

(a) General. Powerex warrants each Compressor System, Vacuum System, Vacuum Pump, Compressor Air-End, or Powerex branded Accessory (collectively “Products”, individually each a “Product”) to be free from defects in material and workmanship (“Defects”) at the date of shipment. This warranty shall apply only to Products that are purchased and used in the United States of America and in Canada. EXCEPT AS SET FORTH BELOW, NO OTHER WARRANTY, WHETHER EXPRESS OR IMPLIED, INCLUDING ANY WARRANTY OF MERCHANTABILITY OR FITNESS FOR A PARTICULAR PURPOSE, SHALL EXIST IN CONNECTION WITH THE SALE OR USE OF SUCH PRODUCTS. TO THE EXTENT PERMITTED BY LAW, ANY AND ALL IMPLIED WARRANTIES ARE EXCLUDED. All warranty claims must be made in writing and delivered to Powerex in accordance with the procedures set forth on its website (www.powerexinc.com), or such claim shall be barred. Upon timely receipt of a warranty claim, Powerex shall inspect the Product claimed to have a Defect, and Powerex shall repair, or, at its option, replace, free of charge, any Product which it determines to have had a Defect; provided, however, that if circumstances are such as to preclude the remedying of Defect by repair or replacement, Powerex shall, upon return of the Product, refund to buyer any part of the purchase price of such Products paid to Powerex. Freight for returning Products to Powerex for inspection shall be paid by buyer. The warranties and remedies herein are the sole and exclusive remedy for any breach of warranty or for any other claim based on any Defect, or non-performance of the Products, whether based upon contract, warranty or negligence.

(b) (i) Standard Period of Warranty – Parts and Labor - The purchase of any system includes our standard warranty. Powerex warrants and represents all Products shall be free from Defects for the first eighteen (18) months from the date of shipment by Powerex, or twelve (12) months from the documented date of startup, or five thousand (5,000) hours of use, whichever occurs first. During such warranty period, Powerex shall be fully liable for all Defects in the Products (the “Product Defects”), i.e., all costs of repair or replacement, which may include “in and out” charges, so long as the Products are located in the United States or Canada, and the Products are reasonably located and accessible by service personnel for removal. “In and out” charges include the costs of removing a Product from buyer’s equipment for repair or replacement.

(ii) Premium Period of Warranty – Parts and Labor - In order to be eligible for premium warranty coverage, a premium warranty for each system must be purchased when order is placed. Powerex warrants and represents all Products shall be free from Defects for the first thirty (30) months from the date of shipment by Powerex, or twenty-four (24) months from the documented date of startup, or seven thousand five hundred (7,500) hours of use, whichever occurs first. During such warranty period, Powerex shall be fully liable for all Defects in the Products (the “Product Defects”), i.e., all costs of repair or replacement, which may include “in and out” charges, so long as the Products are located in the United States or Canada, and the Products are reasonably located and accessible by service personnel for removal. “In and out” charges include the costs of removing a Product from buyer’s equipment for repair or replacement.

(c) Additional Period of Warranty – Parts Only (No Labor). In addition to the above, Powerex warrants each Powerex branded Compressor Air-End and Vacuum Pump shall be free of Defects for a period of forty-two (42) months from the date of shipment by Powerex, or thirty-six (36) months from the documented date of startup, or ten thousand (10,000) hours of use, whichever occurs first. Supplier’s repair or replacement of any Product shall not extend the period of any warranty of any Product. This warranty applies to the exchange of part(s) found to be defective by an Authorized Powerex Service Representative only.

(d) Replacement Pumps – Parts Only (No Labor). For any replacement Air-End or Vacuum Pumps installed on a Powerex manufactured system or unit after any initial warranty period has expired or where another warranty does not apply for any reason, Powerex warrants that the Air-End or Vacuum Pumps shall be free of Defects for a period of thirty-six (36) months from the date of shipment by Powerex or ten thousand (10,000) hours of use, whichever comes first. For any replacement Air-End or Vacuum Pumps installed on a system that was not manufactured by Powerex after any initial warranty period has expired or where another warranty does not apply for any reason, Powerex warrants that the Air-End or Vacuum Pumps shall be free of Defects for the first twelve (12) months from the date of shipment by Powerex. Supplier’s repair or replacement of any Product shall not extend the period of any warranty of any Product. This warranty applies to the exchange of part(s) found to be defective by an Authorized Powerex Service Representative only.

(e) Replacement Motors – Parts Only (No Labor). For any replacement motor installed on a Powerex manufactured system or unit after any initial warranty period has expired or where another warranty does not apply for any reason, Powerex warrants that the replacement motor shall be free of Defects for the first twelve (12) months from the date of shipment by Powerex. For any replacement motor installed on a system or unit that was not manufactured by Powerex after any initial warranty period has expired or where another warranty does not apply for any reason, Powerex warrants that the replacement motor shall be free of Defects for the first ninety (90) days from the date of shipment by Powerex. Supplier’s repair or replacement of any Product shall not extend the period of any warranty of any Product. This warranty applies to the exchange of part(s) found to be defective by an Authorized Powerex Service Representative only.

(f) Replacement Parts – Parts Only (No Labor). For other replacement parts besides motors, Air-End or Vacuum Pumps installed on a Powerex manufactured system or unit after any initial warranty period has expired or where another warranty does not apply for any reason, Powerex warrants that such replacement parts will be free from Defects for the first twelve (12) months from the date of shipment by Powerex. For other replacement parts besides motors, Air-End or Vacuum Pumps installed on a system or unit that was not manufactured by Powerex after any initial warranty period has expired or where another warranty does not apply for any reason, Powerex makes no warranties. Supplier’s repair or replacement of any Product shall not extend the period of any warranty of any Product. This warranty applies to the exchange of part(s) found to be defective by an Authorized Powerex Service Representative only.

(g) Coverage. The warranty provided herein applies to Powerex manufactured units or systems only.

(h) Exceptions. Notwithstanding anything to the contrary herein, Powerex shall have no warranty obligations with respect to Products:

- (i) that have not been installed in accordance with Powerex’s written specifications and instructions;
- (ii) that have not been maintained in accordance with Powerex’s written instructions;
- (iii) that have been materially modified without the prior written approval of Powerex; or
- (iv) that experience failures resulting from operation, either intentional or otherwise, in excess of rated capacities or in an otherwise improper manner.

(i) The warranty provided herein shall not apply to:

- (i) any defects arising from corrosion, abrasion, use of insoluble lubricants, or negligent attendance to or faulty operation of the Products;
- (ii) ordinary wear and tear of the Products;
- (iii) defects arising from abnormal conditions of temperature, dirt or corrosive matter; or
- (iv) any OEM component which is shipped by Powerex with the original manufacturer’s warranty, which shall be the sole applicable warranty for such component.

Limitation of Liability. NOTWITHSTANDING ANYTHING TO THE CONTRARY HEREIN, TO THE EXTENT ALLOWABLE UNDER APPLICABLE LAW, UNDER NO CIRCUMSTANCES SHALL POWEREX BE LIABLE FOR ANY INCIDENTAL, CONSEQUENTIAL, PUNITIVE, SPECULATIVE OR INDIRECT LOSSES OR DAMAGES WHATSOEVER ARISING OUT OF OR IN ANY WAY RELATED TO ANY OF THE PRODUCTS OR GOODS SOLD OR AGREED TO BE SOLD BY POWEREX TO BUYER. TO THE EXTENT ALLOWABLE UNDER APPLICABLE

Oilless Reciprocating Air Compressor Pumps

LAW, POWEREX'S LIABILITY IN ALL EVENTS IS LIMITED TO, AND SHALL NOT EXCEED, THE PURCHASE PRICE PAID.

Warranty Disclaimer. Powerex has made a diligent effort to illustrate and describe the Products in its literature, including its Price Book, accurately; however, such illustrations and descriptions are for the sole purpose of identification, and do not express or imply a warranty that the Products are merchantable, or fit for a particular purpose, or that the Products will necessarily conform to the illustrations or descriptions.

Product Suitability. Many jurisdictions have codes and regulations governing sales, construction, installation, and/or use of Products for certain purposes, which may vary from those in neighboring areas. While Powerex attempts to assure that its Products comply with such codes, it cannot guarantee compliance, and cannot be responsible for how the product is installed or used. Before purchase and use of a Product, please review the Product applications, and national and local codes and regulations, and be sure that the Product, installation, and use will comply with them.

Claims. Any non-warranty claims pertaining to the Products must be filed with Powerex within 6 months of the invoice date, or they will not be honored. Prices, discounts, and terms are subject to change without notice or as stipulated in specific Product quotations. Powerex shall not be liable for any delay or failure arising out of acts of the public enemy, fire, flood, or any disaster, labor trouble, riot or disorder, delay in the supply of materials or any other cause, whether similar or dissimilar, beyond the control of Company. All shipments are carefully inspected and counted before leaving the factory. Please inspect carefully any receipt of Products noting any discrepancy or damage on the carrier's freight bill at the time of delivery. Discrepancies or damage which obviously occurred in transit are the carrier's responsibility and related claims should be made promptly directly to the carrier. Returned Products will not be accepted without prior written authorization by Powerex and deductions from invoices for shortage or damage claims will not be allowed. **UNLESS OTHERWISE AGREED TO IN WRITING, THE TERMS AND CONDITIONS CONTAINED IN THIS LIMITED WARRANTY WILL CONTROL IN ANY TRANSACTION WITH POWEREX.** Any different or conflicting terms as may appear on any order form now or later submitted by the buyer will not control. All orders are subject to acceptance by Powerex.

PORTLAND
COMPRESSOR
Experience You Can Depend On
800-542-8300