



Technical drawing of a screw compressor assembly. The drawing shows a cross-section of the compressor with various components labeled with numbers and dimensions. Key dimensions include 47, 31, 10.8, 30.8, 4.18, 18.5, and 10.5. A large circular component is shown with a hatched pattern and a curved arrow indicating rotation. The drawing is overlaid on a blue background.

Atlas Copco

**PORTLAND
COMPRESSOR**
Experience You Can Depend On
800-542-8300

Instruction book

Oil-injected screw compressors

GA 15, GA 18, GA 22, GA 26, GA 30

**PORTLAND
COMPRESSOR**
Experience You Can Depend On
800-542-8300

Atlas Copco

Oil-injected screw compressors

GA 15, GA 18, GA 22, GA 26, GA 30

Instruction book

Original instructions

WARNING



Read all safety warnings, instructions, illustrations and specifications provided with this product. Failure to follow all instructions listed in this instruction book may result in personal injury, death and/or property damage.

COPYRIGHT NOTICE

Any unauthorized use or copying of the contents or any part thereof is prohibited.

This applies in particular to trademarks, model denominations, part numbers and drawings.

This instruction book is valid for CE, non-CE as well as UKCA labelled machines. It meets the requirements for instructions specified by the applicable European directives or UK statutory instruments as identified in the Declaration of Conformity.

September 2023

No. 2920 7216 11

www.atlascopco.com

Atlas Copco

Table of contents

1	Safety precautions.....	6
1.1	SAFETY ICONS.....	6
1.2	GENERAL SAFETY PRECAUTIONS.....	6
1.3	SAFETY PRECAUTIONS DURING INSTALLATION.....	8
1.4	SAFETY PRECAUTIONS DURING OPERATION.....	9
1.5	SAFETY PRECAUTIONS DURING MAINTENANCE OR REPAIR.....	10
1.6	DISMANTLING AND DISPOSAL.....	12
2	Introduction.....	13
3	Operation.....	17
4	Electrical system.....	21
5	Electrical diagrams.....	22
6	Air dryer.....	23
7	Elektronikon™ Swipe controller.....	24
7.1	CONTROLLER.....	24
7.2	CONTROL PANEL.....	26
7.3	ICONS USED.....	27
7.4	MENU.....	28
7.5	MAIN SCREEN.....	30
7.6	SHUTDOWN.....	33
7.7	MACHINE SETTINGS MENU.....	34
7.8	AUXILIARY EQUIPMENT PARAMETERS MENU.....	36



7.9	DATA MENU.....	38
7.10	SERVICE MENU.....	39
7.11	CONTROLLER SETTINGS MENU.....	40
7.12	INFORMATION MENU.....	42
7.13	WEB SERVER.....	43
7.14	PROGRAMMABLE SETTINGS.....	49
8	Elektronikon™ Touch controller.....	53
8.1	CONTROLLER.....	53
8.2	CONTROL PANEL.....	55
8.3	ICONS USED.....	55
8.4	MAIN SCREEN.....	59
8.5	QUICK ACCESS SCREEN.....	61
8.6	SHUTDOWN WARNING.....	61
8.7	SHUTDOWN.....	62
8.8	MENU SCREEN.....	65
8.9	DATA MENU.....	67
8.10	SERVICE MENU.....	69
8.11	WEEK TIMER MENU.....	71
8.12	EVENT HISTORY MENU.....	71
8.13	MACHINE SETTINGS MENU.....	72
8.14	CONTROLLER SETTINGS MENU.....	75
8.15	ACCESS LEVEL.....	78
8.16	WEB SERVER.....	79
8.17	PROGRAMMABLE SETTINGS.....	85



9	Installation.....	87
9.1	DIMENSION DRAWINGS.....	87
9.2	INSTALLATION PROPOSAL.....	88
9.3	ELECTRICAL CONNECTIONS.....	90
9.4	PICTOGRAPHS.....	91
10	Energy recovery.....	93
10.1	ENERGY RECOVERY (ER) UNIT.....	93
10.2	ENERGY RECOVERY (ER) SYSTEMS.....	94
10.3	ENERGY RECOVERY (ER) OPERATION.....	95
10.4	ENERGY RECOVERY (ER) MAINTENANCE.....	98
10.5	COOLING WATER REQUIREMENTS.....	98
10.6	ENERGY RECOVERY (ER) DATA.....	103
11	Operating instructions.....	105
11.1	INITIAL START UP.....	105
11.2	STARTING.....	105
11.3	DURING OPERATION.....	107
11.4	STOPPING.....	109
11.5	TAKING OUT OF OPERATION.....	111
12	Maintenance.....	112
12.1	PREVENTIVE MAINTENANCE SCHEDULE.....	112
12.2	OIL SPECIFICATIONS.....	116
12.3	STORAGE AFTER INSTALLATION.....	118
12.4	SERVICE KITS.....	118

PORTLAND
 COMPRESSOR
Experience You Can Depend On
 800-542-8300

13	Adjustments and servicing procedures.....	119
13.1	DRIVE MOTOR.....	119
13.2	AIR FILTER.....	119
13.3	OIL AND OIL FILTER CHANGE.....	120
13.4	OIL SEPARATOR CHANGE.....	121
13.5	COOLERS.....	121
13.6	SAFETY VALVES.....	121
13.7	DRYER MAINTENANCE INSTRUCTIONS.....	122
14	Problem solving.....	123
15	Technical data.....	126
15.1	READINGS ON DISPLAY.....	126
15.2	ELECTRIC CABLE SIZE AND MAIN FUSES.....	127
15.3	MOTOR OVERLOAD RELAY SETTINGS.....	130
15.4	DRYER SWITCHES.....	131
15.5	REFERENCE CONDITIONS AND LIMITATIONS.....	131
15.6	COMPRESSOR DATA.....	132
15.7	TECHNICAL DATA OF CONTROLLER.....	139
16	Instructions for use.....	141
17	Guidelines for inspection.....	142
18	Pressure equipment directives.....	143
19	Declaration of conformity.....	144

PORTLAND
COMPRESSOR

Experience You Can Depend On

800-542-8300

1 Safety precautions

1.1 Safety icons



DANGER

Indicates an imminently hazardous situation which, if not avoided, will result in death or serious injury.



WARNING

Indicates a potentially hazardous situation which, if not avoided, could result in death or serious injury.



NOTICE

Indicates a potential situation which, if not avoided, might result in property damage or in an undesirable result or state.



NOTE

Indicates important information.

1.2 General safety precautions

- The operator must employ safe working practices and observe all related work safety requirements and regulations.
- If any of the following statements does not comply with the applicable legislation, the stricter of the two shall apply.
- Installation, operation, maintenance and repair work must only be performed by authorized, trained, specialized personnel. The personnel should apply safe working practices by use of personal protection equipment, appropriate tools and defined procedures.
- The compressor is not considered capable of producing air of breathing quality. For air of breathing quality, the compressed air must be adequately purified according to the applicable legislation and standards.
- Before any maintenance, repair work, adjustment or any other non-routine checks, switch the controller in service mode (see section *Service mode*), stop the compressor, press the emergency stop button, switch off the voltage and depressurize the compressor. In addition, the power isolating switch must be opened and locked. The process of locking, tagging and trying to turn on the equipment to confirm it cannot operate is called Lock Out, Tag Out (LOTO).

On units powered by a frequency converter, wait 10 minutes after switching off the voltage, before starting any electrical repair.

WARNING

In a domestic environment, this product may cause conducted and irradiated interference, in which case supplementary mitigation measures are required.

DANGER

If the machine is equipped with an automatic restart after voltage failure function and if this function is active, be aware that the machine will restart automatically when the power is restored if it was running when the power was interrupted!

- Never play with compressed air. Do not apply the air to your skin or direct an air stream at people. Never use the air to clean dirt from your clothes. When using the air to clean equipment, do so with extreme caution and wear eye protection.
- The owner is responsible for maintaining the unit in safe operating condition. Parts and accessories shall be replaced if unsuitable for safe operation.
- It is not allowed to walk or stand on the unit or on its components.
- If compressed air is used in the food industry and more specifically for direct food contact, it is recommended, for optimal safety, to use certified Class 0 compressors in combination with appropriate filtration depending on the application. Please contact your customer center for advice on specific filtration.
- The service switch should only be operated by a trained service specialist from the manufacturer.

Safety precautions for the connectivity module

It is important to follow all regulations regarding the use of radio equipment, in particular regarding the possibility of radio frequency (RF) interference. Please follow the safety advice given below carefully.

- Respect restrictions on the use of radio equipment in fuel depots, chemical plants or other explosive environments.
- Avoid operation close to inadequately protected personal medical devices such as hearing aids and pacemakers. Consult the manufacturers of the medical device to determine if it is adequately protected.
- Avoid operation close to other electronic equipment which may also cause interference if the equipment is inadequately protected. Observe any warning signs and manufacturer recommendations.
- Respect a distance from the human body of at least 20 cm (8 inch) during operation.
- Do not operate the device in areas where cellular modems without proper device certifications are not advised. These areas include environments where cellular radio can interfere, such as atmospheres with explosives, medical equipment, or any other equipment which may be susceptible to any form of radio interference. The modem can transmit signals that could interfere with this equipment.

1.3 Safety precautions during installation

WARNING



All responsibility for any damage or injury resulting from neglecting these precautions, or non-observance of the normal caution and care required for installation, operation, maintenance and repair, even if not expressly stated, will be disclaimed by the manufacturer.

- The machine must only be lifted using suitable equipment in accordance with the applicable safety regulations. Loose or pivoting parts must be securely fastened before lifting. It is strictly forbidden to dwell or stay in the risk zone under a lifted load. Lifting acceleration and deceleration must be kept within safe limits. Wear a safety helmet when working in the area of overhead or lifting equipment.
- The unit is designed for indoor use. If the unit is installed outdoors, special precautions must be taken. Consult your supplier.
- Place the machine where the ambient air is as cool and clean as possible. If necessary, install a suction duct. Never obstruct the air inlet. Care must be taken to minimize the entry of moisture at the inlet air.
- Any blanking flanges, plugs, caps and desiccant bags must be removed before connecting the pipes.
- Air hoses must be of correct size and suitable for the working pressure. Never use frayed, damaged or worn hoses. Distribution pipes and connections must be of the correct size and suitable for the working pressure.
- The aspirated air must be free of flammable fumes, vapors and particles, e.g. paint solvents, that can lead to internal fire or explosion.
- Arrange the air intake so that loose clothing worn by people cannot be drawn in.
- Ensure that the discharge pipe from the compressor to the after-cooler or air net is free to expand under heat and that it is not in contact with or close to flammable materials.
- No external force may be exerted on the air outlet valve; the connected pipe must be free of strain.
- If remote control is installed, the machine must bear a clear sign stating: DANGER: This machine is remotely controlled and may start without warning.

The operator has to make sure that the machine is stopped and depressurized and that the electrical isolating switch is open, locked and labelled with a temporary warning before any maintenance or repair. As a further safeguard, persons switching on or off remotely controlled machines shall take adequate precautions to ensure that there is no one checking or working on the machine. To this end, a suitable notice shall be affixed to the start equipment.

- Air-cooled machines must be installed in such a way that an adequate flow of cooling air is available and that the exhausted air does not recirculate to the compressor air inlet or cooling air inlet.
- The electrical connections must correspond to the applicable codes. The machines must be earthed and protected against short circuits by fuses in all phases. A lockable power isolating switch must be installed near the compressor.
- On machines with automatic start/stop system or if the automatic restart function after voltage failure is activated, a sign stating "This machine may start without warning" must be affixed near the instrument panel.
- In multiple compressor systems, manual valves must be installed to isolate each compressor. Non-return valves (check valves) must not be relied upon for isolating pressure systems.

- Never remove or tamper with the safety devices, guards or insulation fitted on the machine. Every pressure vessel or auxiliary installed outside the machine to contain air above atmospheric pressure must be protected by a pressure relieving device or devices as required.
- Piping or other parts with a temperature in excess of 70°C (158°F) and which may be accidentally touched by personnel in normal operation must be guarded or insulated. Other high temperature piping must be clearly marked.
- If the ground is not level or can be subject to variable inclination, consult the manufacturer.
- In an installation with multiple compressors, the outlet piping must be installed in such a way that condensate cannot flow back into the compressor. See section *Installation proposal*.

NOTE



Also consult the following safety precautions: ***Safety precautions during operation*** and ***Safety precautions during maintenance or repair***.

These precautions apply to machinery processing or consuming air or inert gas. Processing of any other gas requires additional safety precautions typical to the application which are not included herein.

Some precautions are general and cover several machine types and equipment; hence some statements may not apply to your machine.

1.4 Safety precautions during operation

WARNING



All responsibility for any damage or injury resulting from neglecting these precautions, or non-observance of the normal caution and care required for installation, operation, maintenance and repair, even if not expressly stated, will be disclaimed by the manufacturer.

- Never touch any piping or components of the machine during operation.
- Use only the correct type and size of hose end fittings and connections. When blowing through a hose or air line, ensure that the open end is held securely. A free end will whip and may cause injury. Make sure that a hose is fully depressurized before disconnecting it.
- Persons switching on remotely controlled machines shall take adequate precautions to ensure that there is no one checking or working on the machine. To this end, a suitable notice shall be affixed to the remote start equipment.
- Never operate the machine when there is a possibility of taking in flammable or toxic fumes, vapors or particles.
- Never operate the machine below or in excess of its limit ratings.
- Keep all bodywork doors shut during operation. The doors may be opened for short periods only, e.g. to carry out routine checks. Wear ear and eye protection when opening a door.

On machines without bodywork, wear ear protection in the vicinity of the machine.

- People staying in environments or rooms where the sound pressure level reaches or exceeds 80 dB(A) shall wear ear protectors.
- Periodically check that:
 - All guards are in place and securely fastened
 - All hoses and/or pipes inside the machine are in good condition, secure and not rubbing
 - No leaks occur

- All fasteners are tight
- All electrical leads are secure and in good order
- Safety valves and other pressure relief devices are not obstructed by dirt or paint
- Air outlet valve and air net, i.e. pipes, couplings, manifolds, valves, hoses, etc. are in good repair, free of wear or abuse
- All pre-filters are not clogged
- If warm cooling air from compressors is used in air heating systems, e.g. to warm up a workroom, take precautions against air pollution and possible contamination of the breathing air.
- Do not remove any of, or tamper with, the sound-damping material.
- Never remove or tamper with the safety devices, guards or insulations fitted on the machine. Every pressure vessel or auxiliary installed outside the machine to contain air above atmospheric pressure shall be protected by a pressure relieving device or devices as required.
- Yearly inspect the air receiver. Minimum wall thickness as specified in the instruction book must be respected. Local regulations remain applicable if they are more strict.

NOTE



Also consult the following safety precautions: *Safety precautions during operation* and *Safety precautions during maintenance or repair*.

These precautions apply to machinery processing or consuming air or inert gas. Processing of any other gas requires additional safety precautions typical to the application which are not included herein.

Some precautions are general and cover several machine types and equipment; hence some statements may not apply to your machine.

1.5 Safety precautions during maintenance or repair

WARNING



All responsibility for any damage or injury resulting from neglecting these precautions, or non-observance of the normal caution and care required for installation, operation, maintenance and repair, even if not expressly stated, will be disclaimed by the manufacturer.

- Always use the correct safety equipment (such as safety glasses, gloves, safety shoes, etc.).
- Use only the correct tools for maintenance and repair work.
- Use only genuine spare parts for maintenance or repair. The manufacturer will disclaim all damage or injuries caused by the use of non-genuine spare parts.
- All maintenance work shall only be undertaken when the machine has cooled down.
- A warning sign bearing a legend such as "Work in progress; do not start" shall be attached to the starting equipment.
- Persons switching on remotely controlled machines shall take adequate precautions to ensure that there is no one checking or working on the machine. To this end, a suitable notice shall be affixed to the remote start equipment.
- Close the compressor air outlet valve and depressurize the compressor before connecting or disconnecting a pipe.

- Before removing any pressurized component, effectively isolate the machine from all sources of pressure and relieve the entire system of pressure. See section *Maintenance*.
- Never use flammable solvents or carbon tetrachloride for cleaning parts. Take safety precautions against toxic vapors of cleaning liquids.
- Scrupulously observe cleanliness during maintenance and repair. Keep dirt away by covering the parts and exposed openings with a clean cloth, paper or tape.
- Never weld or perform any operation involving heat near the oil system. Oil tanks must be completely purged, e.g. by steam cleaning, before carrying out such operations. Never weld on, or in any way modify, pressure vessels.
- Whenever there is an indication or any suspicion that an internal part of a machine is overheated, the machine shall be stopped but no inspection covers shall be opened before sufficient cooling time has elapsed; this to avoid the risk of spontaneous ignition of the oil vapor when air is admitted.
- Never use a light source with open flame for inspecting the interior of a machine, pressure vessel, etc.
- Make sure that no tools, loose parts or rags are left in or on the machine.
- When replacing the air filter, make sure no dirt, dust, rags, tools or loose parts can fall in the air inlet.
- All regulating and safety devices shall be maintained with due care to ensure that they function properly. They may not be put out of action.
- Before clearing the machine for use after maintenance or overhaul, check that operating pressures, temperatures and time settings are correct. Check that all control and shut-down devices are fitted and that they function correctly. If removed, check that the coupling guard of the compressor drive shaft has been reinstalled.
- Every time the separator element is renewed, examine the discharge pipe and the inside of the oil separator vessel for carbon deposits; if excessive, the deposits should be removed.
- Protect the motor, air filter, electrical and regulating components, etc. to prevent moisture from entering them, e.g. when steam cleaning.
- Make sure that all sound-damping material and vibration dampers, e.g. damping material on the bodywork and in the air inlet and outlet systems of the compressor, is in good condition. If damaged, replace it by genuine material from the manufacturer to prevent the sound pressure level from increasing.
- Never use caustic solvents which can damage materials of the air net, e.g. polycarbonate bowls.
- **Only if applicable, the following safety precautions are stressed when handling refrigerant:**
 - Never inhale refrigerant vapors. Check that the working area is adequately ventilated; if required, use breathing protection.
 - Always wear special gloves. In case of refrigerant contact with the skin, rinse the skin with water. If liquid refrigerant contacts the skin through clothing, never tear off or remove the latter; flush abundantly with fresh water over the clothing until all refrigerant is flushed away; then seek medical first aid.
- Protect hands to avoid injury from hot machine parts, e.g. during draining of oil.
- Be aware of eventual sharp edges on certain parts of the machine.

**NOTE**

Also consult the following safety precautions: *Safety precautions during operation* and *Safety precautions during maintenance or repair*.

These precautions apply to machinery processing or consuming air or inert gas. Processing of any other gas requires additional safety precautions typical to the application which are not included herein.

Some precautions are general and cover several machine types and equipment; hence some statements may not apply to your machine.

1.6 Dismantling and disposal

The device must be disposed according to local regulations. The product is not designed for refurbishing after finished lifecycle.

Dismantling

Once the end of life of the machine is reached, please follow next steps:

1. Stop the machine.
2. Check all safety precautions mentioned in the previous chapters to secure safe handling (e.g. LOTO, cool-down, depressurize, discharge, etc.).
3. Have trained personnel dismantle the installation.
4. Separate the harmful from the safe components (e.g. drain oil from parts containing oil).
5. Refer to the disposal topic below.

Disposal of electrical and electronic appliances (WEEE)

This equipment falls under the provisions of the European Directive 2012/19/EU on waste electrical and electronic appliances (WEEE) as well as under the UKCA Waste Electrical and Electronic Equipment regulations 2013 and may not be disposed as unsorted waste.

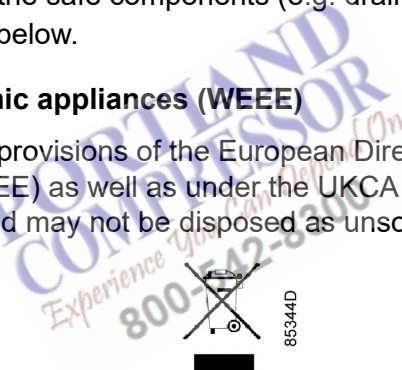

The equipment is labelled in accordance with the European Directive 2012/19/EU and the UKCA Waste Electrical and Electronic Equipment regulations 2013 with the crossed-out wheeled bin symbol.

At the end of life-time of the electric and electronic equipment (EEE) it must be taken to separate collection.

For more information check with your local waste authority, customer center or distributor.

Disposal of other used material

Used filters or any other used material (e.g. filter bags, filter media, desiccant, lubricants, cleaning rags, machine parts, etc.) must be disposed of in an environmentally friendly and safe manner, and in line with the local recommendations and environmental legislation.

2 Introduction

GA 15, GA 18, GA 22, GA 26 and GA 30 are single-stage, oil-injected screw compressors driven by an electric motor. The compressors are air-cooled. The compressors are enclosed in a sound insulating bodywork.

The compressors are controlled by an Elektronikon™ controller, fitted to the door on the front side. The cabinet with electrical equipment is located behind the door panel.

The compressors are available in two versions: the floor-mounted version and the tank-mounted version. Each of these versions can be supplied without integrated air dryer (Pack version) or with integrated air dryer (Full-Feature version).

GA Pack

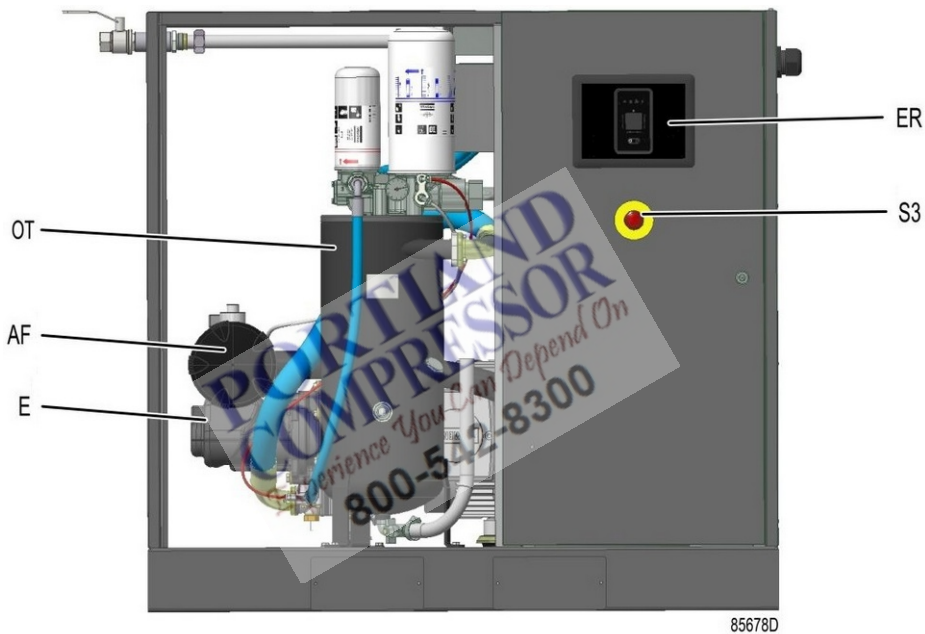

Figure 1: Front view GA 22 P, floor-mounted

Reference	Description
ER	Elektronikon™ controller
S3	Emergency stop button
E	Compressor element
OT	Oil separator tank
AF	Air filter

On the receiver-mounted version, the compressor is mounted on a large air receiver (AR) of 500 l (132 US gal):



Figure 2: Front view GA 22 P, receiver-mounted

Reference	Description
ER	Elektronikon™ controller
S3	Emergency stop button
Dm	Manual drain, air receiver
AR	Air receiver
AV	Air outlet valve

GA Full-Feature

GA Full-Feature (FF) compressors are provided with an air dryer, integrated in the canopy. The dryer removes condensate from the compressed air by cooling the air to near freezing point and automatically draining the condensate.

Floor-mounted compressors are directly installed on the floor:

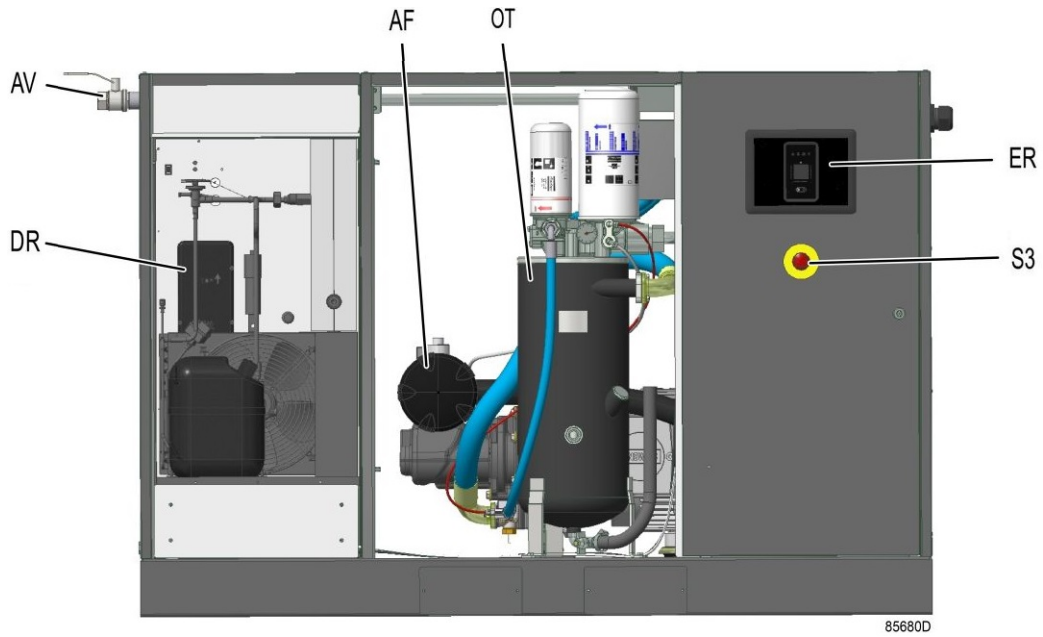

Figure 3: Front view GA 22 FF, floor-mounted

Reference	Description
ER	Elektronikon™ controller
S3	Emergency stop button
DR	Dryer
OT	Oil separator tank
AF	Air filter
AV	Air outlet valve

On the receiver-mounted version, the compressor is mounted on a large air receiver (AR) of 500 l (132 US gal):

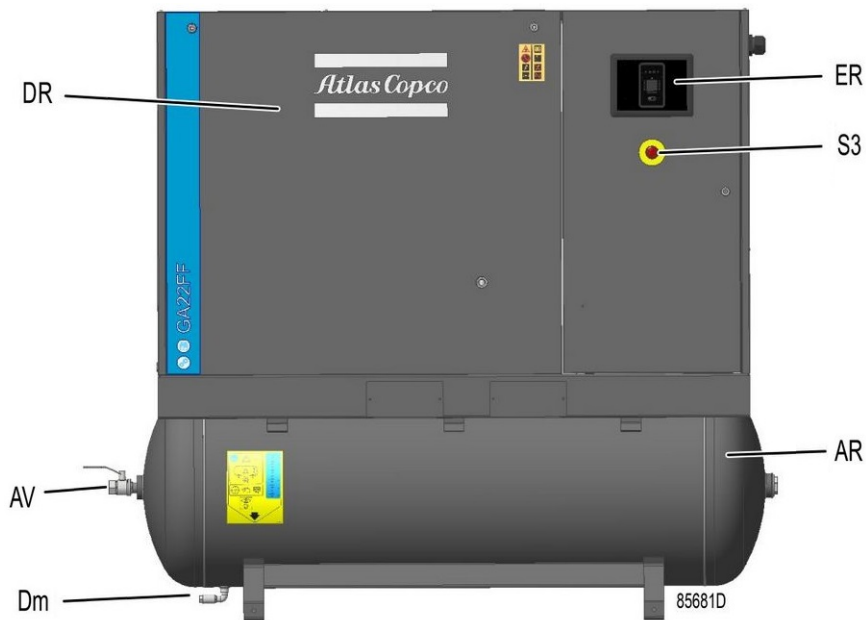

Figure 4: Front view GA 22 FF, receiver-mounted

Reference	Description
ER	Elektronikon™ controller
S3	Emergency stop button
Dm	Manual drain, air receiver
AR	Air receiver
AV	Air outlet valve
DR	Dryer

**PORTLAND
COMPRESSOR**
Experience You Can Depend On
800-542-8300

3 Operation

Flow diagrams - Pack

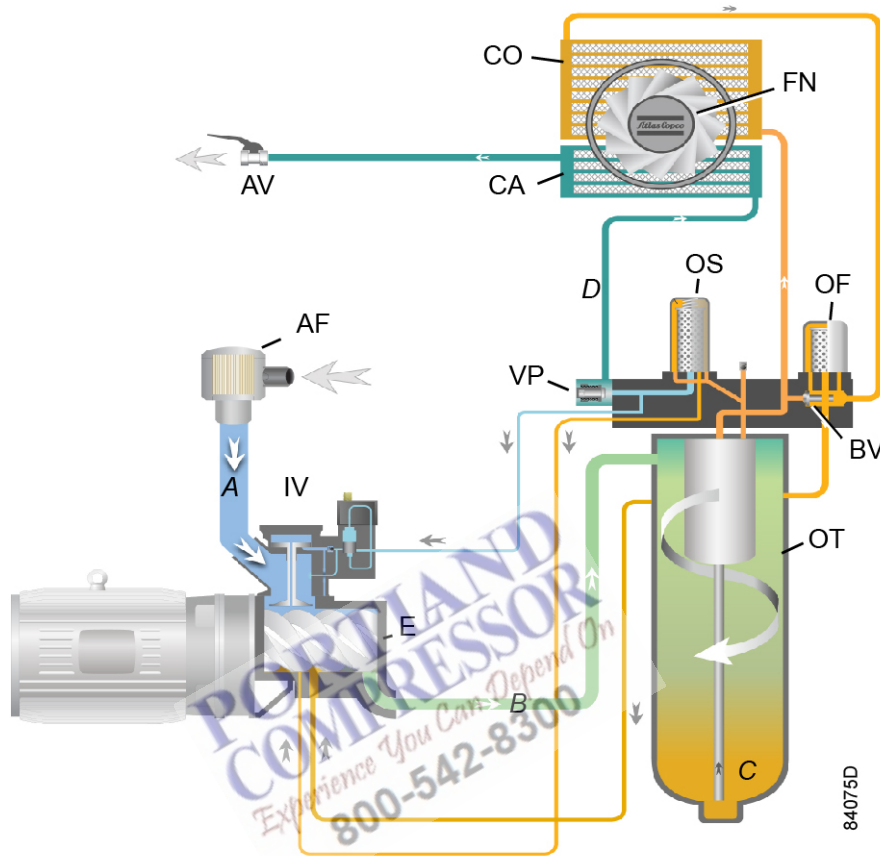

Figure 5: Flow diagram, GA Pack

Reference	Description
A	Intake air
B	Air/oil mixture
C	Oil
D	Wet compressed air
E	Condensate

On compressors without integrated dryer, the air flows directly to the outlet valve (AV).

On compressors with integrated dryer, the air flows through the air dryer (DR) before it is discharged through the outlet valve (AV). See section *Air dryer* for details on the operation of the dryer.

During operation, minimum pressure valve (Vp) keeps the pressure in the separator tank (OT) above a minimum value, required for lubrication. An integrated check valve prevents the compressed air downstream the valve from being vented to atmosphere during unloaded operation.

When the compressor is stopped, the inlet valve (IV) closes, preventing compressed air and oil to flow to the air filter.

Regulation

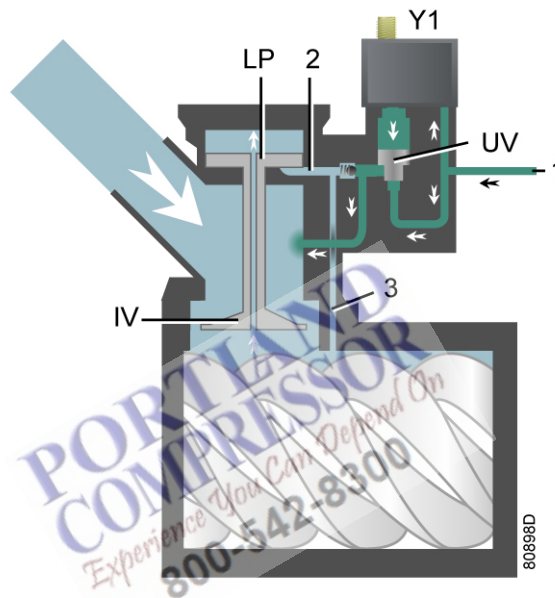

Figure 7: Unloading valve (loaded condition)

- When the net pressure is below the loading pressure, the solenoid valve (Y1) is energized.
 - The space above the unloading valve/blow-off valve (UV) is connected with the oil separator tank pressure (1) via the solenoid valve.
 - The unloading valve/blow-off valve (UV) moves downwards, closing off the connection to channels (2) and (3).
 - The underpressure from the compressor element causes loading plunger (LP) to move downwards and the inlet valve (IV) to open fully.

Result: air delivery is 100%, the compressor runs loaded.

- If the air consumption is less than the air output of the compressor, the net pressure increases. When the net pressure reaches the unloading pressure, the solenoid valve (Y1) is de-energized.
 - The pressure above the unloading valve/blow-off valve (UV) is released to the atmosphere and the space above the valve (UV) is no longer in connection with the oil separator tank pressure (1).
 - The unloading valve/blow-off valve (UV) moves upwards, connecting the oil separator tank pressure (1) with channels (2) and (3).

- The pressure in channel (2) causes the loading plunger (LP) to move upwards, causing the inlet valve (IV) to close, while the pressure is gradually released to atmosphere.
- The pressure in the separator tank stabilizes at low value. A small amount of air is kept drawn in to guarantee a minimal pressure required for lubrication during unloaded operation.

Result: air output is stopped, the compressor runs unloaded.

Oil flow

In the oil separator tank (OT), most of the oil is removed from the air/oil mixture by centrifugal action. The oil collects in the lower part of oil tank. The remaining oil is separated from the compressed air by the oil separator element (OS).

Air pressure forces the oil from the oil tank (OT) through the oil cooler (Co) and filter (OF) to the compressor element (E).

The oil system is provided with a thermostatic bypass valve (BV). When the oil temperature is below its set point, the bypass valve (BV) shuts off the supply to the oil cooler (Co) and the oil cooler is bypassed.

The thermostatic bypass valve (BV) starts opening the supply from cooler (Co) when the oil temperature has increased to the set point. At approximately 15 °C (27 °F) above the set point, all the oil flows through the oil cooler.

Cooling

The cooling system comprises an air cooler (Ca) and an oil cooler (Co).

The cooling flow is generated by the fan (FN).

Condensate removal

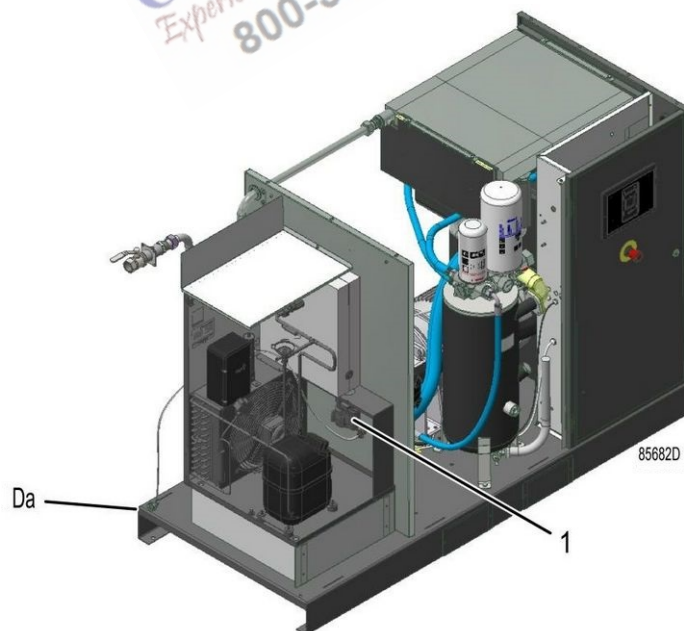

On Full-Feature units, the dryer is equipped with an electronic drain (1). The electronic drain is provided with an automatic drain outlet (Da).

Tank mounted units are provided with an additional manual drain on the air receiver.

4 Electrical system

General

Also consult sections *Electrical diagrams* and *Electrical connections*.

Electrical components

The electrical system comprises following components:

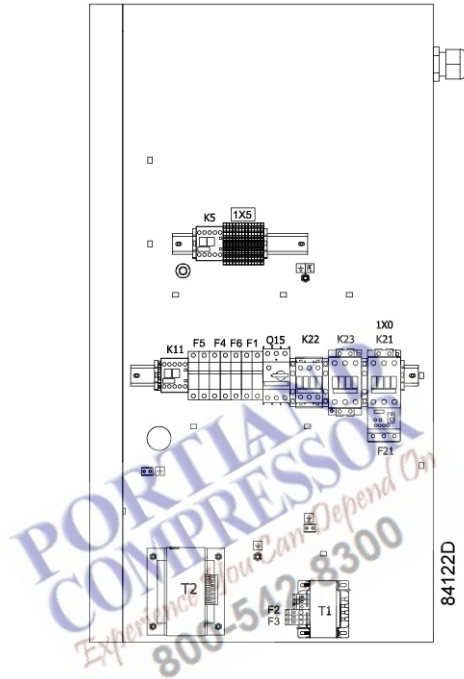

Figure 8: Electrical cubicle, typical example

Reference	Designation
F1...6	Fuses
K5	Auxiliary relay
F21	Overload relay, compressor motor
K11	Auxiliary contactor for dryer (only on Full-Feature compressors)
K21	Line contactor
K22	Star contactor
K23	Delta contactor
Q15	Circuit breaker, fan motor
T1/T2	Transformers
1X0	Terminal strip (voltage supply)
1X1	Terminal strip (motor)
1X5	Terminal strip (Control circuit)
PE	Earth terminal

5 Electrical diagrams

The complete electrical diagram can be found in the electrical cubicle.

**PORTLAND
COMPRESSOR**
Experience You Can Depend On
800-542-8300

6 Air dryer

Description

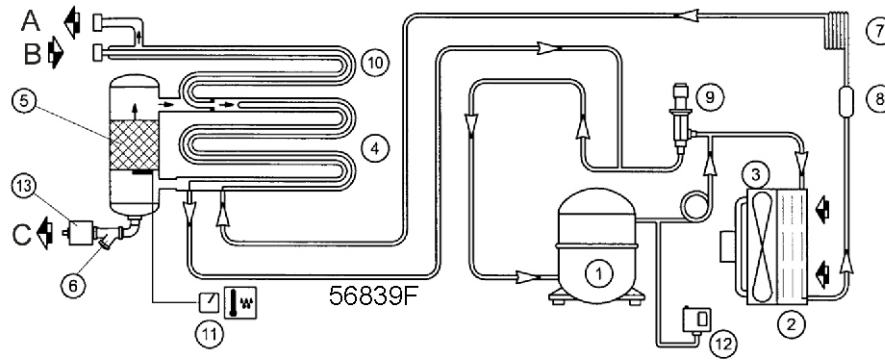

Figure 9: Air dryer

Air circuit

Compressed air enters the heat exchanger (10) and is cooled by the outgoing, cold, dried air. Water vapor in the incoming air starts to condense. The air then flows through the heat exchanger/evaporator (4) where the refrigerant evaporates, causing the air to be cooled further to near the evaporating temperature of the refrigerant. More water condenses. The cold air then flows through the separator (5) where all the condensate is separated from the air. The condensate is automatically drained. The cold, dried air flows through the heat exchanger (10) where it is warmed up by the incoming air.

Refrigerant circuit

The refrigerant compressor (1) delivers hot, high-pressure refrigerant gas which flows through the condenser (2) where most of the refrigerant condenses.

The liquid refrigerant flows through the dryer/filter (8) to the capillary tube (7). The refrigerant leaves the capillary tube at evaporating pressure.

The refrigerant enters the evaporator (4) where it withdraws heat from the compressed air by further evaporation at constant pressure. The heated refrigerant leaves the evaporator and is sucked in by the compressor (1).

8 Elektronikon™ Touch controller

8.1 Controller



Figure 18: The Elektronikon™ Touch controller

Introduction

The controller has the following functions:

- Controlling the unit
- Protecting the unit
- Monitoring components subject to service
- Automatic Restart After Voltage Failure (ARAVF)

Automatic control of the unit

The controller maintains the net pressure between programmable limits by automatically loading and unloading the unit (fixed speed units) or by adapting the motor speed (units with frequency converter).

A number of programmable settings, e.g. the unloading and loading pressures (for fixed speed units), the setpoint (for units with frequency converter), the minimum stop time, the maximum number of motor starts and several other parameters are taken into account.

The controller stops the unit whenever possible to reduce the power consumption and restarts it automatically when the net pressure decreases. If the expected unloading period is too short, the unit is kept running to prevent too short standstill periods.



It is possible to program a number of time-based commands for automatic start/stop. Take into account that a start command will be executed (if programmed and activated), even after manually stopping the unit.

Protecting the unit

Shutdown

Several sensors are provided on the unit. If one of the measured signals exceeds the programmed shutdown level, the unit will be stopped.

Example: If the element outlet temperature exceeds the programmed shutdown level, the unit will be stopped. This will be indicated on the display of the controller.

The unit will also be stopped in case of overload of the drive motor or fan motor.



Before remedying, consult the *Safety precautions*. Before resetting a warning or shutdown message, always solve the problem. Frequently resetting these messages without remedying may damage the unit.

Shutdown warning

A shutdown warning level is a programmable level below the shutdown level.

If one of the measurements exceeds the programmed shutdown warning level, a message will appear on the display and the general alarm LED will light up to warn the operator before the shutdown level is reached.

The message disappears as soon as the warning condition disappears.

A warning will also appear if the dew point temperature is too high (on units with integrated dryer).

When the shutdown warning is shown, press stop button to stop the unit and wait until the unit has stopped. Switch off the voltage, inspect the unit and remedy if necessary. The warning message will disappear as soon as the warning condition disappears.

Service warning

A number of service operations are grouped as a Service Plan. Each Service Plan has a programmed time interval. If the service timer exceeds a programmed value, this will be indicated on the display to warn the operator to carry out the service actions belonging to that Service Plan.

When the service warning is shown, stop the unit, switch off the voltage and contact your supplier to schedule the necessary maintenance actions. See section **Preventive maintenance schedule**.

Automatic Restart After Voltage Failure (ARAVF)

The controller has a built-in function to automatically restart the unit when the voltage is restored after voltage failure.

For units leaving the factory, this function is made inactive. If desired, the function can be activated. Consult your supplier.



If the function is activated and provided the regulator was in the automatic operation mode, the unit will automatically restart if the supply voltage to the module is restored. The ARAVF label shall be glued next to the controller.

8.2 Control panel



Figure 19: Control panel





























Parts and functions







Reference	Designation	Function
1	Touch screen	Shows the unit operating condition and several icons to navigate through the menu. The screen can be operated by touch.
2	Warning sign	Flashes in case of a shut-down and is lit in case of a warning condition.
3	Service sign	Lit when service is needed.
4	Operation sign	Lit when the unit is running in automatic operation.
5	Voltage sign	Indicates that power is switched on.
6	Stop button	Stops the unit.
7	Start button	Starts the unit. The operation sign (4) lights up. The controller is operative.

8.3 Icons used

Menu icons



Menu	Icon	Menu	Icon	Menu	Icon
Data	85233D	Status	85239D		
		Inputs	85240D		

Menu	Icon	Menu	Icon	Menu	Icon
		Outputs	 85241D		
		Counters	 85242D		
		Aux. Equipment Parameters	 85243D	Converters	 85251D
Service	 85234D	Service		Overview	 85252D
				Service Plan	 85253D
				Service History	 85254D
		Service functions	 85244D		
		Clean Screen	 85302D		
Week Timer	 85235D			Week	 85303D
				Remaining Running Time	 85304D
Event History	 85236D	Saved Data	 85245D		
Machine Settings	 85237D	Alarms	 85239D		
		Regulation	 85346D		
		Control Parameters	 85347D		
		Aux. Equipment Parameters	 85243D	Converter(s)	 85251D
				Fan	 85255D
		Auto Restart	 85274D	Internal SmartBox	 85256D
Controller Settings	 85238D	Network Settings	 85246D	Ethernet Settings	 85257D
				CAN Settings	 85258D

Menu	Icon	Menu	Icon	Menu	Icon
		Localisation	 85247D	Language	 85259D
				Date/Time	 85260D
				Units	 85261D
		User Password	 85248D		
		Help	 85249D		
		Information	 85250D		

Status icons

Icon	Description
 85262D	Motor Stopped
 85263D	Motor Stopped Wait
 85264D	Running Unloaded
 85265D	Manual Unload
 85266D	Running Unloaded Wait
 85267D	Running Loaded
 85268D	Failed to Load
 85269D	Running Loaded Wait
 85270D	Manual Stop
 85271D	Machine Control Mode, Local
 85272D	Machine Control Mode, Remote
 85273D	Machine Control Mode, LAN





 85274D	Automatic Restart After Voltage Failure
 85275D	Week Timer Active

System icons

Icon	Description
 85276D	Basic User
 85277D	Advanced User
 85278D	Service User
 85279D	Antenna 25%
 85280D	Antenna 50%
 85281D	Antenna 75%
 85282D	Antenna 100%
 85283D	Change between screens (indication)
 85284D	Energy recovery
 85285D	Dryer
 85286D	Element
 85287D	Drain(s)
 85288D 4-20mA	Analogue Output
 85289D	Menu
 85290D	Reset
 85291D	Auto Restart

 85292D	Filter(s)
 85293D	Cooler
 85294D	Valve(s)
 85295D	Power Meter

Input icons

Icon	Description
 85296D	Pressure
 85297D	Temperature
 85298D	Special Protection
 85299D	Open
 85300D	Closed

	This chapter gives a general survey of available icons. Not all icons mentioned in this chapter are applicable to every machine.
---	--

8.4 Main screen

Function

The Main screen is the screen that is shown automatically when the voltage is switched on. It is switched off automatically after a few minutes when there is no touch input.

Description

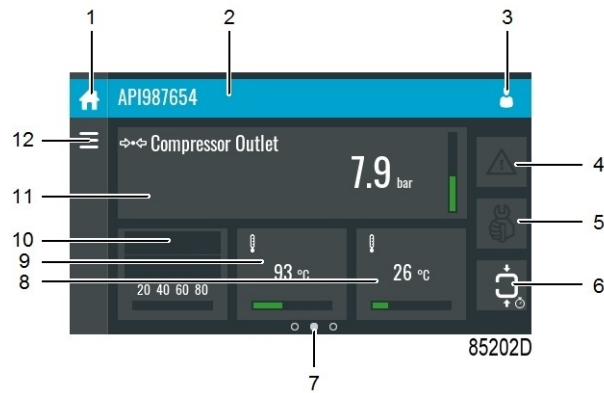

Reference	Designation	Function
1	Home button	The home button is always shown and can be tapped to return to the main screen.
2	Screen information	On the main screen, the screen information bar shows the serial number of the machine. When scrolling through menus, the name of the current menu is shown.
3	Access level button	The access level button is always shown and can be tapped to change the current user access level.
4	Alarm button	The alarm button can be tapped to show the current alarms. If an alarm occurs, the icon on the button will be red.
5	Service button	The service button can be tapped to show the service information.
6	Status	This icon shows the current status of the unit.
7	Page indicator	Indicates which page you currently see. The middle indication is the main screen, left is the menu screen and at the right the quick access screen. Swipe left or right to go to another screen.
8, 9, 10, 11	These fields can contain a history chart, an input or a counter value, depending on the type of the machine.	Tap the field to view the type of measurement. This will be shown in the screen information bar. Examples of inputs: <ul style="list-style-type: none"> Ambient temp Outlet Dryer dewpoint Examples of counters: <ul style="list-style-type: none"> Running hours Load relay Loaded hours
12	Menu button	The menu button is always shown and can be tapped to go to the menu.

8.5 Quick access screen

Function

The screen is used to directly access some frequently used functions.

Procedure

The Quick access screen can be viewed by swiping left, starting from the main screen.

Description

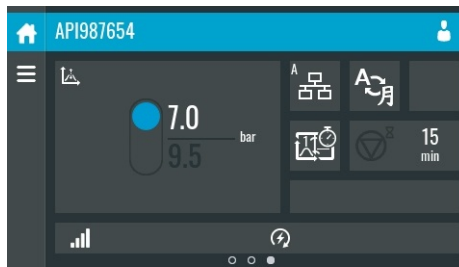

85201D

Through this screen, several important settings can be viewed and modified.

Function	Description
Setpoints	Several setpoints can be modified by tapping this icon.
Control mode	<p>The control mode can be changed by tapping this icon.</p> <ul style="list-style-type: none"> Local control via start/stop buttons Remote control via digital input(s) LAN control via the network. <p>When in Remote or LAN control, the start/stop buttons on the controller will not work.</p>
Display language	The display language of the controller can be changed by tapping this icon.
Manual unload (only on fixed speed units)	When tapped, the machine will go in Manual unload mode until the icon is tapped again.
Week timer	Week timers can be set by tapping this icon.
Remaining running time	The Remaining running time can be set and modified by tapping this icon.
Internal SmartBox	<p>The reception quality of the internal antenna can be monitored.</p>  <p>Each bar represents 25% reception strength. If the four bars are filled, the reception strength is 100%. If only one bar is filled, the reception strength is just 25%.</p>
Auto restart	Auto restart can be activated by tapping this icon.

8.6 Shutdown warning

If the element outlet temperature exceeds the shutdown warning level (see section Programmable Settings), warning LED (2) will light up and a yellow warning icon (4) is shown in the upper side of the display as in below image:



85695D

Tap on the select warning icon (4) to see the Status menu.

In case of element outlet temperature warning, the display will appear as below:

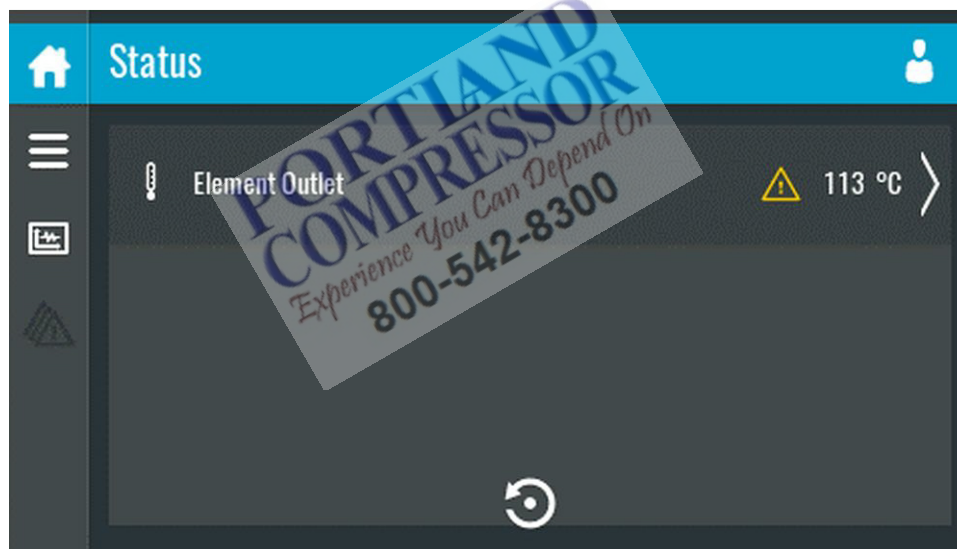

85696D

It remains possible to scroll through other screens, to check the actual status of other parameters. Press stop key (7) to stop the unit and wait until the unit has stopped. Switch off the voltage, inspect the unit and remedy. The warning message will disappear as soon the warning condition disappears.

8.7 Shutdown

Description

The unit will be shut down in following circumstances:

- In case the temperature at the outlet of the element exceeds the programmed shutdown level (detected by temperature sensor (TT11) or by temperature switch (TSHH11)).

- In case of too high air/oil temperature (detected by additional temperature switch (TSHH21)).
- In case of overload of the motor (M1) or the fan motor (M2).
- In case of error of the outlet pressure sensor (PT20).
- In case of incorrect phase sequence, detected by phase sequence relay (K25).
- In case of overtemperature of the motor windings, detected by thermistor relay (K34).

Element outlet temperature (TT11)

If the element outlet temperature, measured by temperature sensor TT11, exceeds the shutdown level (see section Programmable settings), the unit will be shutdown, alarm LED (2) will flash, automatic operation LED (4) will go out and the following screen will appear:

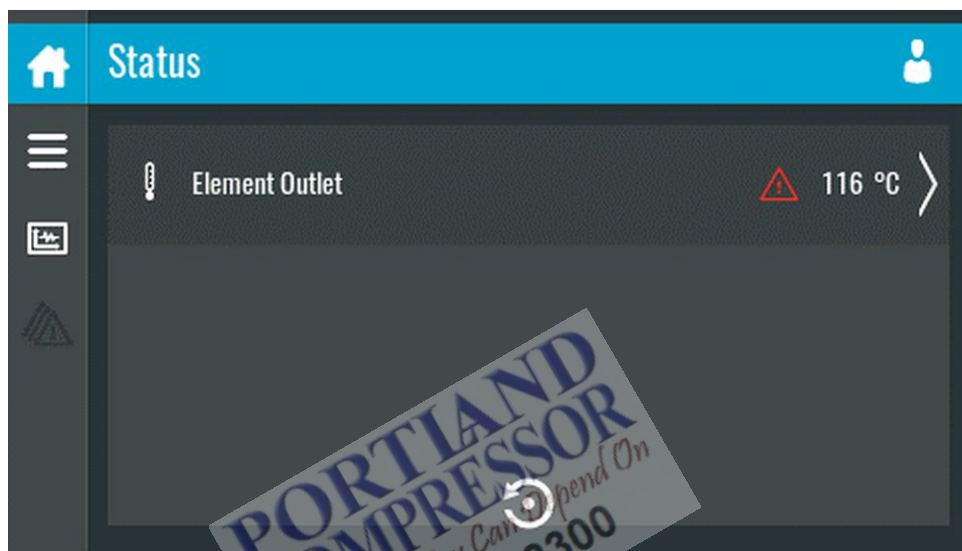

85697D

Figure 20: Status screen with shutdown indication

Press on shutdown indication on the screen.

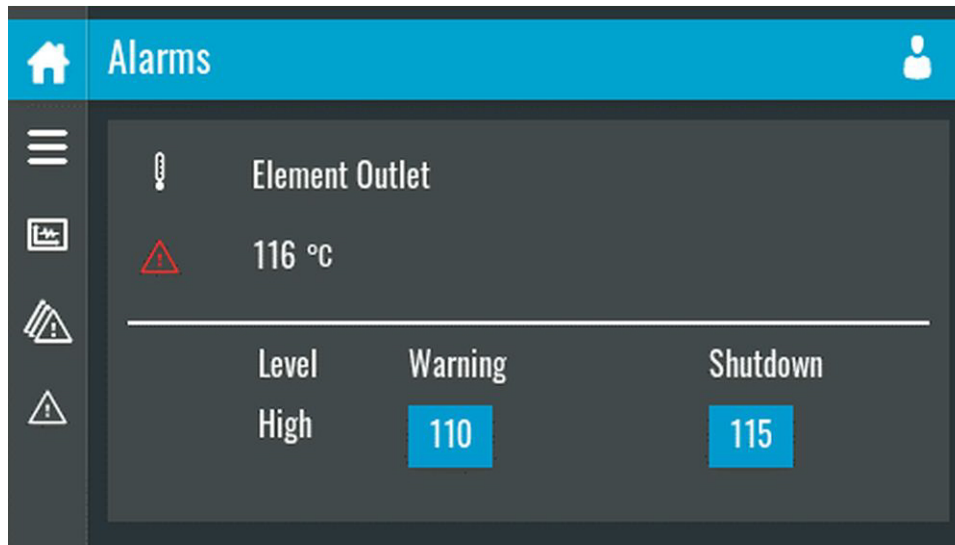

85698D

Figure 21: Shutdown screen, element outlet temperature

The above screen shows that the temperature at the outlet of the element is 116 °C. Actions:

- Switch off the voltage and remedy the problem cause.
- After remedying and when the shutdown condition has disappeared, switch on the voltage and restart the unit.

Other shutdown causes

In case the unit is shut down (or cannot start) by one of following causes:

- Too high element outlet temperature, detected by temperature switch (TSHH11) or additional temperature switch (TSHH21).
- Overload of the motor (M1) or the fan motor (M2).
- Incorrect phase sequence, detected by phase sequence relay (K25).
- In case of overtemperature of the motor windings, detected by thermistor relay (K34).

The unit will be shutdown, alarm LED (2) will flash, automatic operation LED (4) will go out and following screen will appear:

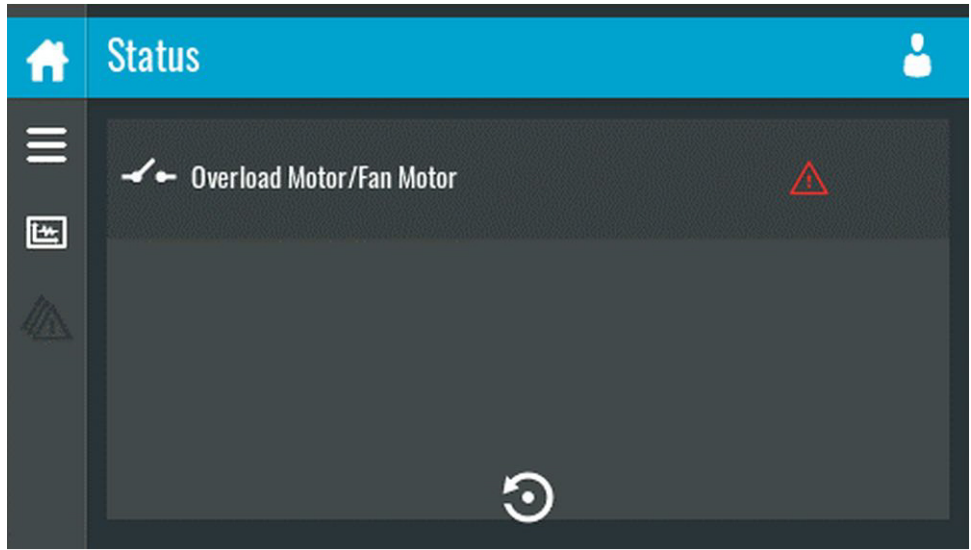

85699D

Figure 22: Main screen with shutdown indication

Actions:

- Switch off the voltage and remedy the problem cause.
- In case of incorrect phase sequence, reverse two phases of the supply cable.
- If the additional temperature switch (TSHH21) has tripped, you must contact the Atlas Copco customer center.
- After remedying and when the shutdown condition has disappeared, switch on the voltage and restart the unit. The shutdown message will disappear automatically when the shutdown condition has disappeared.

8.8 Menu screen

Function

This screen is used to display the different menus where settings can be viewed or changed.

Procedure

The Menu screen can be viewed by tapping the Menu button or by swiping right, starting from the main screen.

Description

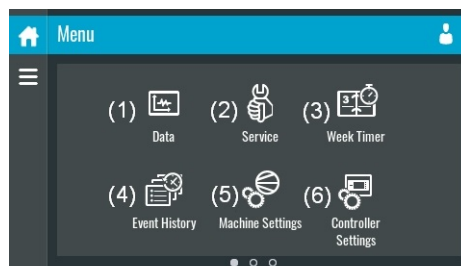

85204D

Reference	Designation	Function
(1)	Data	The data menu contains the status of the unit, information about the Inputs, Outputs and Counters. The Auxiliary equipment can also be viewed through this menu.
(2)	Service	The service menu contains the Service information. The 'Clean screen' function can be used to clean the touchscreen.
(3)	Week timer	Multiple Week timers and a Remaining running time can be set through this menu.
(4)	Event history	In case of an alarm, the Status information of the unit is saved and can be viewed through this menu.
(5)	Machine settings	Alarms settings, Regulation settings and Control parameters can be changed through this menu. Auxiliary equipment parameters can also be changed. The Auto restart function can be set through this menu. This function is password protected.
(6)	Controller settings	Network settings, Localisation settings and a User password can be set through this menu. There is also a Help page available and the Controller information can be shown.

Menu structure

Operating the controller can be done by swiping through screens and tapping icons or menu items.



This is the main menu structure. The structure can be different depending on the configuration of the unit.

8.9 Data menu

Function

This screen is used to display the following submenus:

- Status
- Inputs
- Outputs
- Counters
- Aux. Equipment

These submenus can be entered by tapping the icons.

Procedure

To enter the Data menu screen:

1. Tap the Menu button
2. Tap the Data icon

Description



Reference	Designation
(1)	Status menu
(2)	Inputs menu
(3)	Outputs menu
(4)	Counters menu
(5)	Auxiliary equipment menu

Status menu

Tap the Status icon to enter the Status menu.

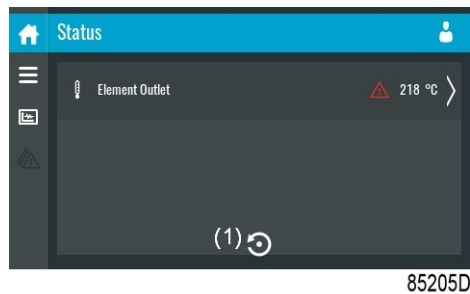

This menu shows the current status of the unit.

If an alarm is active, it can be viewed by tapping the alarm message. To reset an alarm, tap the reset button (1).

	<p>Before remedying, consult the <i>Safety precautions</i>. Before resetting a warning or shutdown message, always solve the problem. Frequently resetting these messages without remedying may damage the unit.</p>
--	--

Inputs menu

Tap the Inputs icon to enter the Inputs menu.

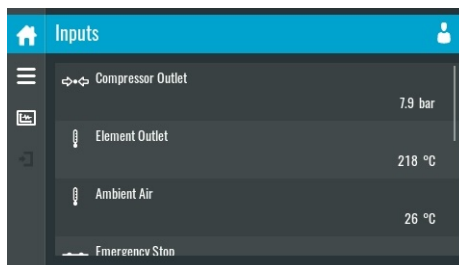

85206D

This menu shows information about all the inputs.

Outputs menu

Tap the Outputs icon to enter the Outputs menu.

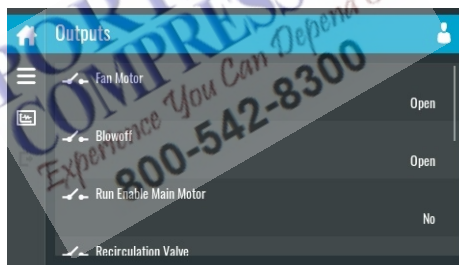

85207D

This menu shows information about all the outputs.

	<p>Voltage-free outputs may only be used to control or monitor functional systems. They should NOT be used to control, switch or interrupt safety related circuits. Check the maximum allowed load on the label.</p>
	<p>Stop the unit and switch off the supply before connecting external equipment. Check the <i>Safety precautions</i>.</p>

Counters menu

Tap the Counters icon to enter the Counters menu.

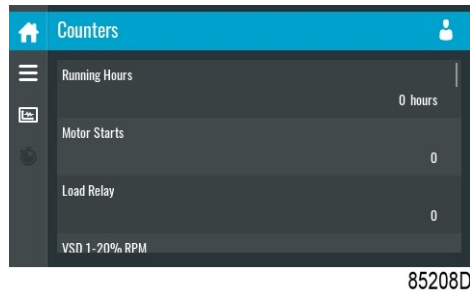

This menu shows an overview of all actual hours and counters of the unit and controller.

Auxiliary equipment menu

Tap the Aux. Equipment icon to enter the Aux. equipment menu.

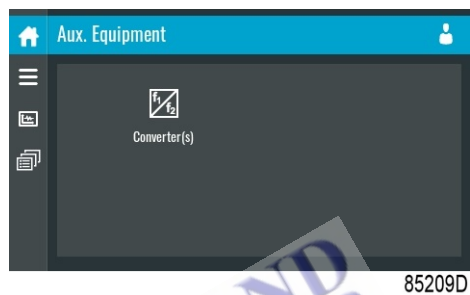

This menu shows an overview of all auxiliary equipment fitted.

8.10 Service menu

Function

This screen is used to display the following submenus:

- Service
- Service functions (Only visible as advanced user)
- Clean screen

These submenus can be entered by tapping the icons.

Procedure

To enter the Service menu screen:

1. Tap the Menu button
2. Tap the Service icon

Description

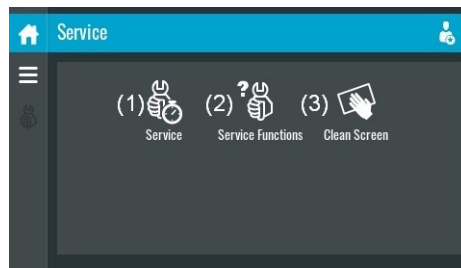

85213D

Reference	Designation
(1)	Service
(2)	Service functions (Only visible as advanced user)
(3)	Clean screen

Service menu

Tap the Service icon to enter the Service menu.

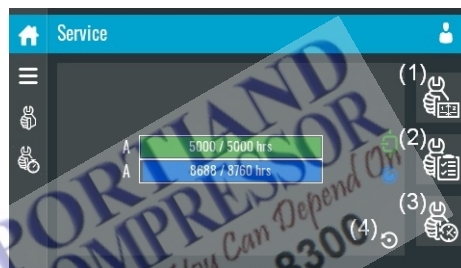

85211D

This menu shows the remaining Running Hours and the remaining Real Time Hours until the next service. The first row (A) shows the Running Hours when the first service is needed (green), the second row shows the Real Time Hours (blue)

A service overview can be viewed by tapping icon (1).

The service history can be viewed by tapping icon (3).

When a service plan interval is reached, a message will appear on the screen.

Clean screen

Tap the Clean Screen icon to start the 15 seconds countdown to perform cleaning of the touchscreen.

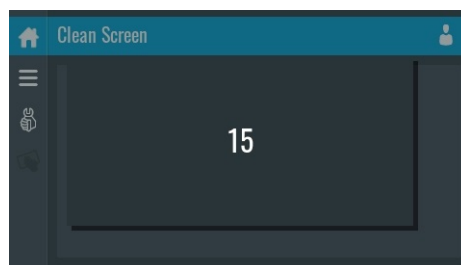

85212D

The touchscreen and the start and stop button become inactive for 15 seconds.

8.11 Week timer menu

Function

This screen is used to set up to 4 different week timers with each up to 8 settings per day.

The week timers can be activated through this screen.

A Remaining Running Time can be set from 5 up to 240 minutes.

Procedure

To enter the Week Timer menu screen:

1. Tap the Menu button
2. Tap the Week Timer icon

Description

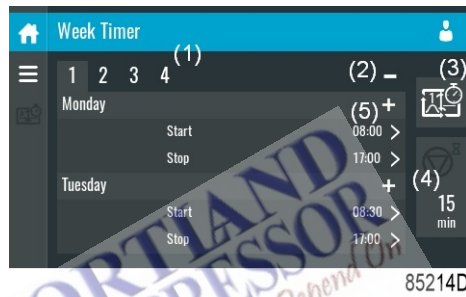

Reference	Designation	Function
(1)	Add or select week	If less than 4 weeks are programmed, tap the '+' button to add a week.
(2)	Remove week	Tap to remove a programmed week timer.
(3)	Activate week timer	A selection screen pops up. The user can choose the correct week by tapping '-' or '+' and can confirm by tapping 'V' or decline by tapping 'X'.
(4)	Remaining running time	A selection screen pops up. The user can change the remaining time by tapping '-' or '+' and can confirm by tapping 'V' or decline by tapping 'X'.
(5)	Add setting	A selection screen pops up. The user can change the setting by swiping up or down and confirm by tapping 'V' or decline by tapping 'X'.

8.12 Event history menu

Function

This screen is used to display the saved data in case of an alarm.

These submenus can be entered by tapping the icons.

Procedure

To enter the Event history menu screen:

1. Tap the Menu button
2. Tap the Event History icon

Description

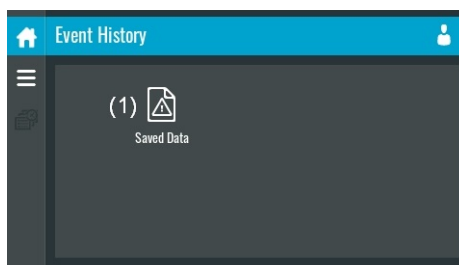

85216D

Reference	Designation
(1)	Saved Data

Saved data

Tap the Saved Data icon to enter the Saved Data menu.

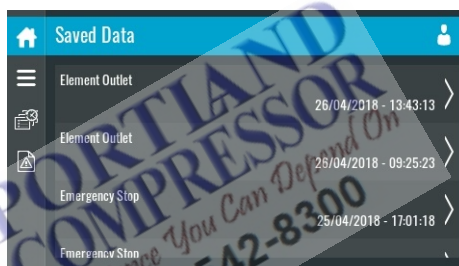

85215D

Scroll through the items swiping up and down in this list. The event date and time is shown at the right side of the screen.

Press on one of the items in the list for more information reflecting the status of the unit when the shutdown occurred.

8.13 Machine settings menu

Function

This screen is used to display the following submenus:

- Alarms
- Regulation
- Control Parameters

Only visible if the machine has adaptable parameters.

- Aux. Equipment parameters
- Auto Restart

These submenus can be entered by tapping the icons.

Procedure

To enter the Machine settings menu screen:

1. Tap the Menu button
2. Tap the Machine Settings icon

Description

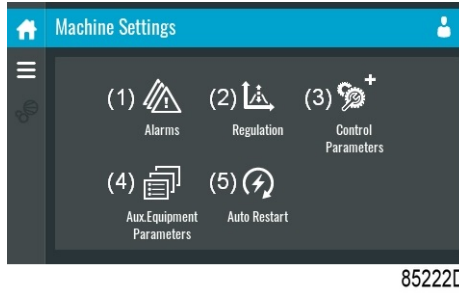

Reference	Designation
(1)	Alarms menu
(2)	Regulation menu
(3)	Control Parameters menu
(4)	Aux. Equipment Parameters menu
(5)	Auto Restart menu

Alarms menu

Tap the Alarms icon to enter the Alarms menu.

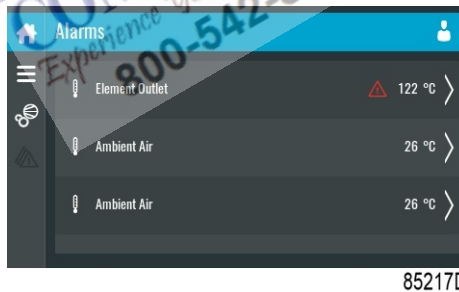

A list of all alarms is shown.

When pressing on one of the items in this list, the warning and/or shutdown levels are shown for this alarm.

Regulation menu

Tap the Regulation icon to enter the Regulation menu.



Setpoints or pressure bands can be modified through this menu.

Modify a setting

When tapping a list item, a selection screen pops up. The user can modify the setting by tapping '–' or '+' and can confirm by tapping 'V' or decline by tapping 'X'.

Change a selection

When tapping a list item, a selection screen pops up. The user can change the selection by swiping up or down and confirm by tapping 'V' or decline by tapping 'X'.

Control parameters menu

Tap the Control Parameters icon to enter the Control Parameters menu.



This menu shows information about the Control Parameters.

Modify a setting

When tapping a list item, a selection screen pops up. The user can modify the setting by tapping '–' or '+' and can confirm by tapping 'V' or decline by tapping 'X'.

Auxiliary equipment parameters menu

Tap the Aux. Equipment Parameters icon to enter the auxiliary equipment parameters menu.

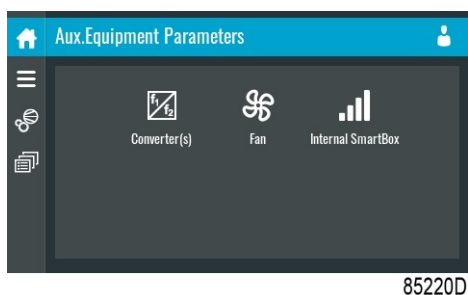

This menu shows an overview of all the auxiliary equipment fitted.

Through this menu, the parameters of the auxiliary equipment can be changed.

Modify a setting

When tapping a list item, a selection screen pops up. The user can modify the setting by tapping ‘–’ or ‘+’ and can confirm by tapping ‘V’ or decline by tapping ‘X’.

Auto restart menu

	<p>If the function is activated and provided the regulator was in the automatic operation mode, the unit will automatically restart if the supply voltage to the module is restored. The ARAVF label shall be glued next to the controller.</p>
--	---

Tap the Auto restart icon to enter the Auto Restart menu.

The controller has a built-in function to automatically restart the unit when the voltage is restored after voltage failure. For units leaving the factory, this function is made inactive. If desired, the function can be activated. Consult your supplier.

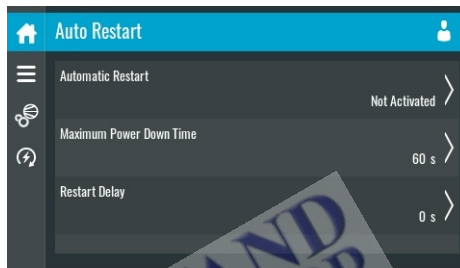

85221D

Through this menu, the automatic restart can be activated. The activation is password protected. The automatic restart settings can also be changed.

Enter a password

When tapping a password protected item, a selection screen pops up. The user can enter the password by swiping up or down to select the desired number. Once the 4 digits are entered, the user can confirm by tapping ‘V’ or decline by tapping ‘X’.

Modify a setting

When clicking a list item, a selection screen pops up. The user can modify the setting by tapping ‘–’ or ‘+’ and can confirm by tapping ‘V’ or decline by tapping ‘X’.

8.14 Controller settings menu

Function

This screen is used to display the following submenus:

- Network Settings
- Localisation
- User Password
- Help
- Information

These submenus can be entered by tapping the icons.

Procedure

To enter the Controller Settings menu screen:

1. Tap the Menu button
2. Tap the Controller Settings icon

Description

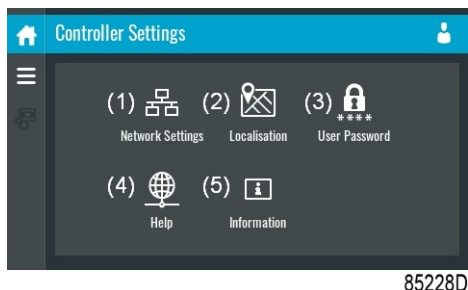

85228D

Reference	Designation
(1)	Network Settings menu
(2)	Localisation menu
(3)	User Password menu
(4)	Help menu
(5)	Information menu

Network settings menu

Tap the Network Settings icon to enter the Network Settings menu.

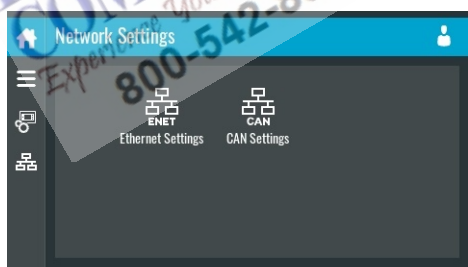

85223D

Ethernet Settings

The list of Ethernet Settings is shown. When ethernet is turned off, the settings can be modified.

CAN Settings

The list of CAN Settings is shown. When CAN is turned off, the settings can be modified.

Modify a setting

When tapping a list item, a selection screen pops up. The user can modify the setting by tapping ‘-’ or ‘+’ and can confirm by tapping ‘V’ or decline by tapping ‘X’.

Change a selection

When tapping a list item, a selection screen pops up. The user can change the selection by swiping up or down and confirm by tapping ‘V’ or decline by tapping ‘X’.

Localisation menu

Tap the Localisation icon to enter the Localisation menu.

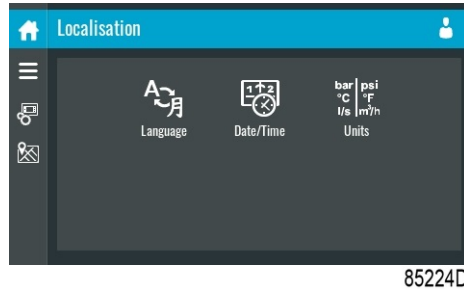

85224D

Language

The language setting of the controller can be modified through this menu.

Date/Time

The date and time settings of the controller can be modified through this menu.

Units

The units displayed can be modified through this menu.

Modify a setting

When tapping a list item, a selection screen pops up. The user can modify the setting by tapping '-' or '+' and can confirm by tapping 'V' or decline by tapping 'X'.

Change a selection

When tapping a list item, a selection screen pops up. The user can change the selection by swiping up or down and confirm by tapping 'V' or decline by tapping 'X'.

User password menu

Tap the User Password icon to enter the User Password menu.

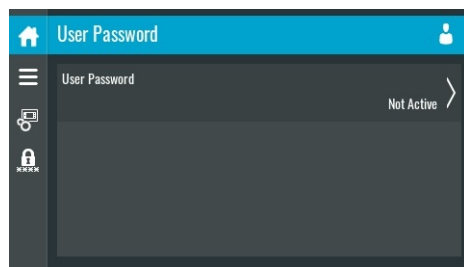

85225D

The user password can be activated or deactivated through this menu. Enter and confirm a user password to activate, repeat to deactivate.

Enter a password

When tapping a password protected item, a selection screen pops up. The user can enter the password by swiping up or down to select the desired number. Once the 4 digits are entered, the user can confirm by tapping 'V' or decline by tapping 'X'.

Help menu

Tap the Help icon to enter the Help menu.

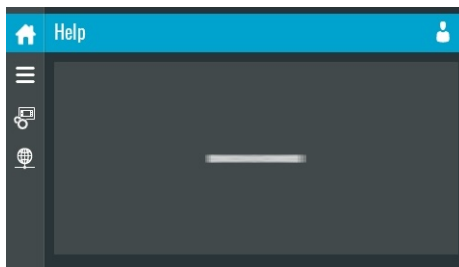

85226D

This menu can show a link to the web page of your supplier, a helpdesk phone number or other helpful information.

Information menu

Tap the Information icon to enter the Information menu.

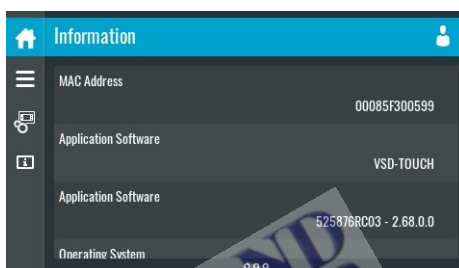

85227D

This menu shows information about the controller.

8.15 Access level

Function

Through this pop-up screen the access level settings can be viewed or changed.

Procedure

The Access Level screen can be viewed or changed by tapping the Access Level button at the upper right corner of the screen.

Description

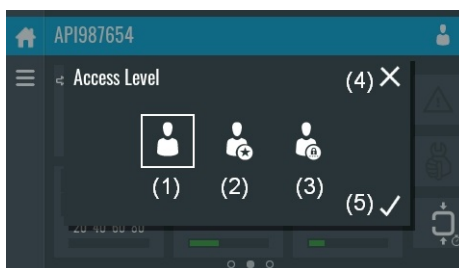

85229D

Reference	Designation	Function
(1)	User	A basic set of parameters is visualized, no password required.
(2)	Service	This access level is only to be used by certified technicians.

Reference	Designation	Function
(3)	Full	This access level is only to be used by certified technicians.
(4)	Decline	Tap to decline the selected user level.
(5)	Confirm	Tap to confirm the selected user level.

8.16 Web server

All controllers have a built-in web server that allows direct connection to the company network or to a dedicated PC via a local area network (LAN). This allows to consult certain data and settings via a PC instead of the display of the controller.

Getting started

Make sure you are logged in as administrator.

- Use the internal network card from your computer or a USB to LAN adapter.
- Use a UTP cable (CAT 5e) to connect to the controller (see picture below).



Configuration of the network card

- Go to Network and Sharing Center (1).

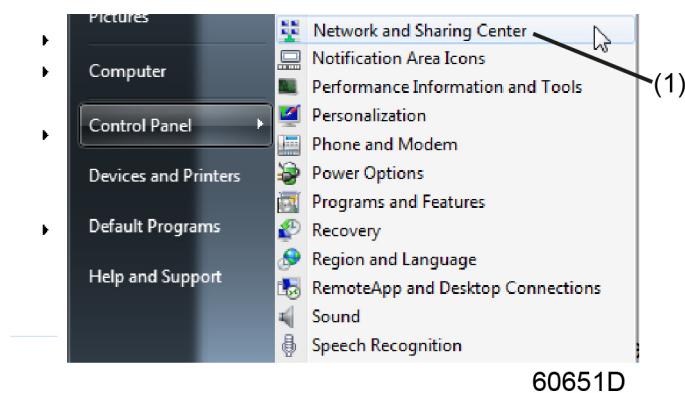

- Click on Change adapter settings (1).

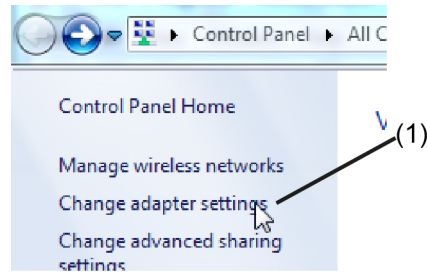

60652D

- Select the Local Area Connection, which is connected to the controller.

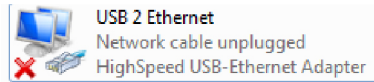

60653D

- Click with the right button and select Properties (1).

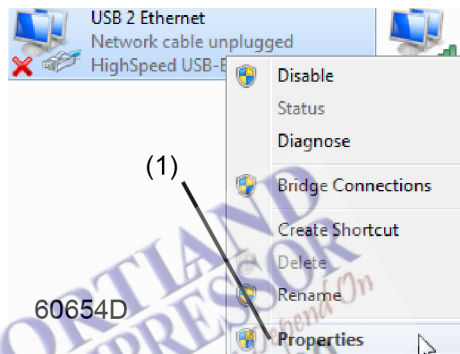

60654D

- Use the check box Internet Protocol version +4 (TCP/IPv4) (1) (see picture). To avoid conflicts, uncheck other properties if they are checked. After selecting TCP/IPv4, click on the Properties button (2) to change the settings.

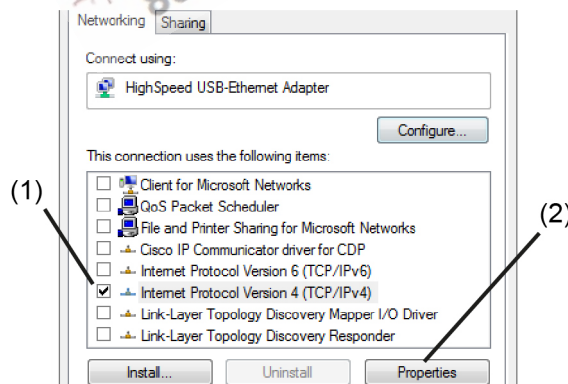

60655D

- Use the following settings:
 - IP Address 192.168.100.200 (1)
 - Subnetmask 255.255.255.0 (2)

Click OK (3) and close network connections.

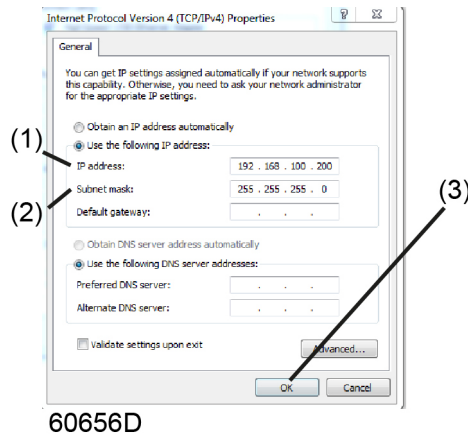

60656D

Configure a company network (LAN) connection

- Ask your IT department to generate a fixed IP address in your company’s network.
- That IP address will be excluded from the DNS server, so it will be reserved for the controller.
- Also get the correct Gateway and Subnet mask settings. For example:
 - IP = 10.25.43.200
 - Gateway = 10.25.42.250
 - Subnet mask = 255.255.254.0
- Connect the controller to the company's network (LAN) by using a UTP cable (min. CAT 5e).



81508D

- Adapt the network settings in the controller.
 - Put the controller in “advanced status”, tap “Controller Settings”, “Network settings”, and at last “Ethernet settings”:

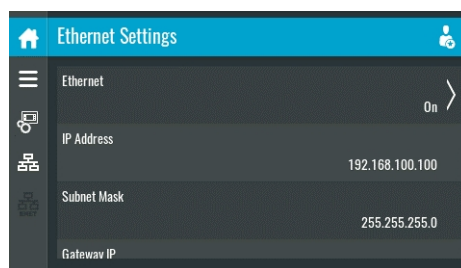

- Switch off the ethernet communication to allow editing the settings:

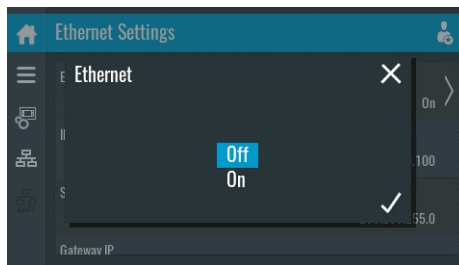

- Adapt IP Address
- Adapt Gateway IP
- Adapt Subnetmask
- Switch on the Ethernet communication
- Wait a few minutes so the controller can be connected to the LAN network

Configuration of the web server

The internal web server is designed and tested for Microsoft® Internet Explorer.

Also "Opera", "Mozilla Firefox", "Safari" and "Chrome" should work.

Viewing the controller data

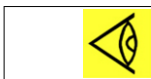

All screen shots are indicative. The number of displayed fields depends on the selected options.

- Open your browser and type the IP address of the controller you want to view in your browser (in this example <http://192.168.100.100>). The interface opens:

81520D

Figure 23: Screen shot (example!)

Navigation and options

- The banner shows the unit type and the language selector. In this example, three languages are available on the controller.



- On the left side of the interface, you can find the navigation menu. If a license for ESi is foreseen, the menu contains 3 buttons.

- Machine: shows all generator settings.
- ES: shows the ESi status (if a license is provided).
- Preferences: allows to change temperature and pressure unit.

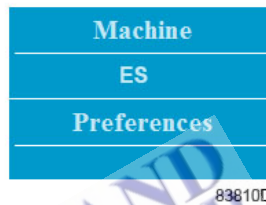

Unit settings

All unit settings can be displayed or hidden. Put a check mark in front of each point of interest and it will be displayed. Only the machine status is fixed and can not be removed from the main screen.

Analog inputs

Lists all current analog input values. The measurement units can be changed in the preference button from the navigation menu.



Counters

Lists all current counter values from controller and unit.



Info status

Machine status is always shown on the web interface.



Digital inputs

Lists all digital inputs and their status.

Digital Inputs

Digital Inputs	Value
Emergency Stop	Closed
Overload Motor/Fan Motor	Closed
Remote Start/Stop	Open
Remote Load/Unload	Open
Remote Pressure Sensing	Open
Pressure Setting Selection	Pressure Band 1

81526D

Digital outputs

Lists all digital outputs and their status.

Digital Outputs

Digital Outputs	Value
Line Contactor	Closed
Star Contactor	Open
Delta Contactor	Closed
Load/Unload	Closed
General Shutdown	Closed
Automatic Operation	Closed
General Warning	Closed

81527D

Special protections

Lists all special protections of the unit.



Service plan

Displays all levels of the service plan and their status. This screen shot underneath only shows the running hours. It is also possible to show the current status of the service interval.



8.17 Programmable settings

Parameters

		Minimum setting	Factory setting	Maximum setting
Number of motor starts	starts/day	0	240	
Minimum stop time	sec	10	20	30
Programmed stop time	sec			
Power recovery time (ARAVF)	sec			3600
Restart delay	sec			1200
Communication time-out	sec	10	30	60

Service plan

The built-in service timers will give a Service warning message after their respective pre-programmed time interval has elapsed.

Also see section *Preventive maintenance schedule*.

Consult Atlas Copco if a timer setting has to be changed. The intervals must not exceed the nominal intervals and must coincide logically. See section *Modifying general settings*.

Terminology

Term	Explanation
ARAVF	Automatic Restart After Voltage Failure. See section <i>Controller</i> and <i>Modifying general settings</i> .
Power recovery time	Is the period within which the voltage must be restored to have an automatic restart. Is accessible if the automatic restart is activated. To activate the automatic restart function, consult Atlas Copco.
Restart delay	This parameter allows to programme that not all compressors are restarted at the same time after a power failure (ARAVF active).
Compressor element outlet	The recommended minimum setting is 70 °C (158 °F). For testing the temperature sensor the setting can be decreased to 50 °C (122 °F). Reset the value after testing. The regulator does not accept illogical settings, e.g. if the warning level is programmed at 95 °C (203 °F), the minimum limit for the shutdown level changes to 96 °C (204 °F). The recommended difference between the warning level and shutdown level is 10 °C (18 °F).
Delay at shutdown signal	Is the time for which the signal must exist before the compressor is shut down. If it is required to program this setting to another value, consult Atlas Copco.
Oil separator	Use only Atlas Copco oil separators. The recommended maximum pressure drop over the oil separator element is 1 bar (15 psi).

Term	Explanation
Minimum stop time	Once the compressor has automatically stopped, it will remain stopped for the minimum stop time, whatever happens with the net air pressure. Consult Atlas Copco if a setting lower than 20 seconds is required.
Unloading/ Loading pressure	The regulator does not accept inconsistent settings, e.g. if the unloading pressure is programmed at 7.0 bar(e) (101 psi(g)), the maximum limit for the loading pressure changes to 6.9 bar(e) (100 psi(g)). The recommended minimum pressure difference between loading and unloading is 0.6 bar (9 psi(g)).

**PORTLAND
COMPRESSOR**
Experience You Can Depend On
800-542-8300

9 Installation

9.1 Dimension drawings

The dimension drawings can be found on the CD or USB delivered with the compressor.

Text on drawings	Translation or explanation
COOLING AIR OUTLET OF COMPRESSOR AND MOTOR	Cooling air outlet of compressor and motor
SERVICE PANEL	Service panel
SERVICE PANEL (OIL SEPARATOR)	Service panel for oil separator element
ELECTRIC CABLE PASSAGE	Electric cable passage
COMPRESSED AIR OUTLET (SUPPLIED LOOSE) IF APPLICABLE	Compressed air outlet valve supplied loose (if applicable)
MANUAL DRAIN	Manual drain
AUTOMATIC DRAIN (EWD WSD OPTION)	Automatic drain (EWD WSD option)
COOLING AIR INLET OF COMPRESSOR AND MOTOR	Cooling air inlet of compressor and motor
AUTOMATIC DRAIN (DRYER)	Automatic drain of the dryer
CENTER OF GRAVITY	(Position of) center of gravity
OIL LEVEL INDICATOR	Oil level indicator
SLOT FOR LIFTING	Slot for lifting
WATER OUTLET (ENERGY RECOVERY OPTION)	Water outlet (Energy recovery option)
WATER INLET (ENERGY RECOVERY OPTION)	Water inlet (Energy recovery option)
ANCHOR POINT (BOTTOM VIEW)	Anchor point (bottom view)
APPROX WEIGHT	Approximate weight
COMPRESSOR MOUNTING HOLES	Compressor mounting holes
* DOOR FULLY OPEN	*: Dimensions with door fully open
TIMER DRAIN	Timed drain
PREFILTER OPTION	Prefilter option
MAIN SWITCH OPTION	Main switch option
3 WAY VALVES (DRYER BYPASS OPTION)	3 way vales (dryer bypass option)
COOLING AIR OUTLET OF DRYER	Cooling air outlet of dryer

9.2 Installation proposal

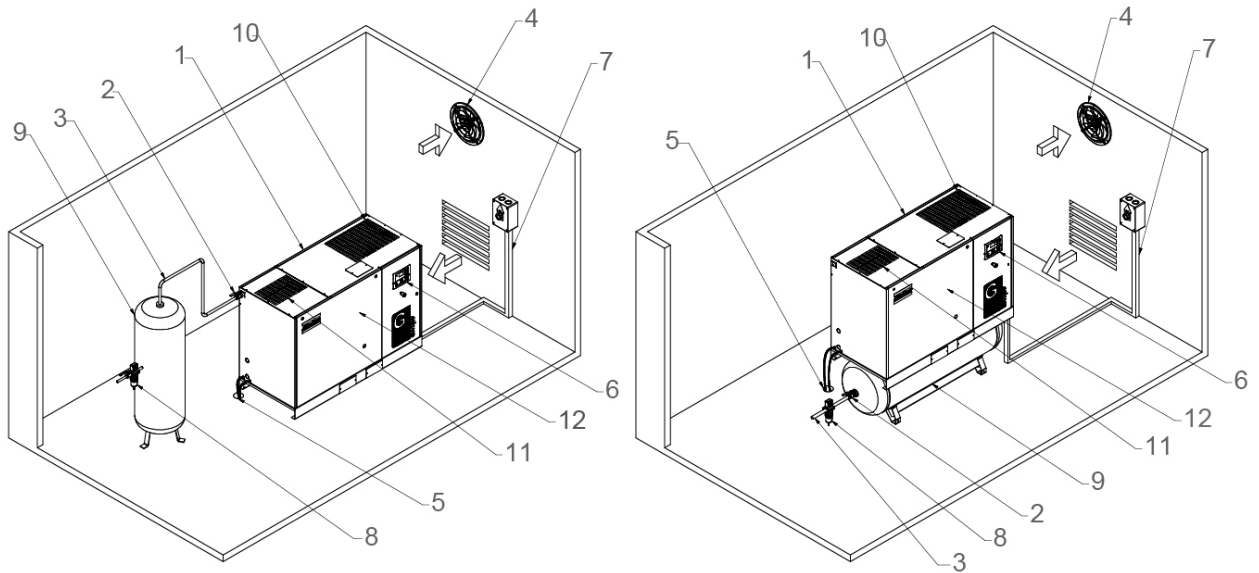

MINIMUM FREE AREA TO BE RESERVED FOR THE COMPRESSOR INSTALLATION

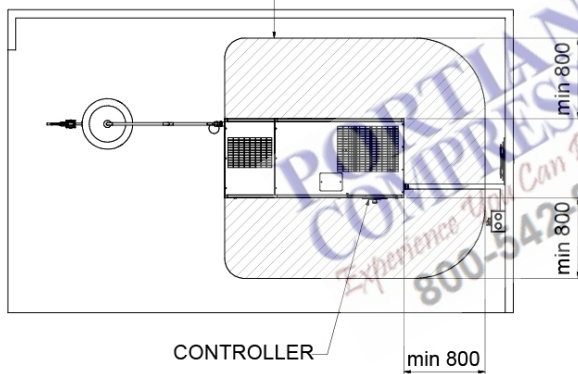

9828 0830 38 Ed 01

84082D

VENTILATION PROPOSALS

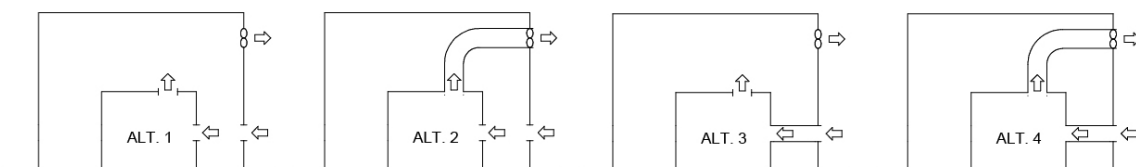

Reference	Description
1	Install the compressor unit on a solid, level floor suitable for taking the weight. Recommended minimum distance between top of the unit and ceiling is 900 mm (35 in). Distance between unit and walls stated are minimum.
2	Position of the compressed air outlet valve.

Reference	Description
3	<p>The pressure drop over the air delivery pipe can be calculated as follows: $\Delta p = (L \times 450 \times Q_c^{1.85}) / (d^5 \times P)$, with d = Inner diameter of the pipe in mm Δp = Pressure drop in bar (recommended maximum: 0.1 bar (1.5 psi)) L = Length of the pipe in m P = Absolute pressure at the compressor outlet in bar Q_c = Free air delivery of the compressor in l/s</p>
4	<p>Ventilation: the inlet grids and ventilation fan should be installed in such a way that any recirculation of cooling air to the compressor is avoided. The maximum air velocity through the grids is 5 m/s (16.5 ft/s). The maximum pressure drop over additional ducts is to be limited to 10 Pa for standard fans. The maximum air temperature at the compressor intake is 46 °C (115 °F) (minimum 0 °C / 32 °F). The ventilation capacity required to limit the compressor room temperature can be calculated from: $Q_v = 0.92 N / \Delta T$ Q_v = Required ventilation capacity in m³/s N = Shaft input of compressor in kW ΔT = Temperature increase in the compressor room in °C</p>
5	<p>The drain pipes to the drain collector must not dip into the water of the drain collector. Install an oil/water separator to ensure that the condensate meets the requirements of the environmental codes. Consult Atlas Copco.</p>
6	<p>Control module with monitoring panel.</p>
7	<p style="text-align: center;">IMPORTANT</p> <div style="display: flex; align-items: center;"> <ul style="list-style-type: none"> • Power supply cable to be sized and installed by a qualified electrician. • To preserve the protection degree of the electrical cubicle and to protect its components from dust from the environment, it is mandatory to use a proper cable gland when connecting the supply cable to the compressor. </div>
8	<p>Filter type DD+ for general purpose filtration (particle removal down to 1 micron with a maximum oil carry over of 0.5 mg/m³). A high efficiency filter type PD+ may be installed downstream the DD+ filter (particle removal down to 0.01 micron and maximum oil carry over of 0.01 mg/m³). If oil vapors and odors are undesirable, a QD type filter can be installed downstream the PD+ filter. It is recommended to install bypass pipes with ball valves over each filter in order to isolate the filters during service operations without disturbing the compressed air delivery.</p>
9	<p>Air receiver: The air receiver must be equipped with a safety valve.</p>
10	<p>Cooling air outlet grating.</p>
11	<p>Cooling air outlet grating of the dryer (FF compressors).</p>
12	<p>Service panel</p>

All pipes to be connected stress free to the compressor!

Safety



WARNING

The operator must apply all relevant safety precautions, including those mentioned in this book.

Outdoor/altitude operation

Fixed speed compressors can be sold with option "rain protection". With this option, this compressor can be installed outside under a shelter, in frost free conditions. If frost might occur, the appropriate measures should be taken to avoid damage to the machine and its ancillary equipment. In this case, and also if operating above 1000 m (3300 ft), consult Atlas Copco.

Moving/lifting

Floor-mounted unit: the compressor can be moved with a lift truck. Take care not to damage any installed connections under the frame while moving the truck or compressor. For lifting make sure that the forks are long enough to provide stable support for the compressor.

Tank-mounted unit: Move the compressor with a lift truck by positioning the forks below the lifting supports that are mounted between the feet of the air receiver. Make sure that the forks are positioned in the centre of the air receiver and lift carefully.

9.3 Electrical connections

Important remark



IMPORTANT

To preserve the protection degree of the electric cubicle and to protect its components from dust from the environment, it is mandatory to use a proper cable gland when connecting the supply cable to the compressor.

Instructions

1. Provide an isolating switch.
2. Check that the motor cables and wires inside the electrical cabinet are clamped tight to their terminals.
3. Check the fuses and the setting of the overload relay. See section *Settings of overload relay and fuses*.
4. Connect the power supply cables to their terminals L1, L2, L3.
5. Connect the neutral conductor to connector (N) if applicable.
6. Connect the earth conductor bolt (PE).

On Full-Feature versions: The supply voltage to the dryer must be 230 V single-phase. The voltage to the dryer is supplied over the contacts of relay (K11), which close when the compressor is started. For compressor supply voltages different from 3 x 400 V plus neutral and 3 x 230 V, the dryer is powered by a transformer.

Compressor control modes on compressors with Elektronikon™ Touch controller

The following control modes can be selected:

- **Local control:** The compressor will react to commands entered by means of the buttons on the control panel. Compressor start/stop commands via Clock function are active, if programmed.
- **LAN control:** The compressor is controlled via a local network. Consult Atlas Copco.

Compressor status indication on compressors equipped with an Elektronikon™ Swipe controller

The Elektronikon™ controller is provided with an auxiliary relay (K05) for remote indication of a shutdown. This NO contact (NO = normally open) will be closed if all conditions are normal and will open in case of power failure or shutdown.

Maximum contact load: 10 A / 250 V AC.

Stop the compressor and switch off the voltage before connecting external equipment. Consult Atlas Copco.

Compressor status indication on compressors equipped with an Elektronikon™ Touch controller

The Elektronikon™ controller is provided with potential free auxiliary NO contacts (NO = normally open) (K05, K07 and K08) for remote indication of:

- Automatic operation (K07)
- Warning condition (K08)
- Shut-down condition (K05)

Example: K05 is a NO (NO = normally open) contact. It will be closed if all conditions are normal and will open in case of power failure or shutdown.

Maximum contact load: 10 A / 250 V AC.

Stop the compressor and switch off the voltage before connecting external equipment. Consult Atlas Copco.

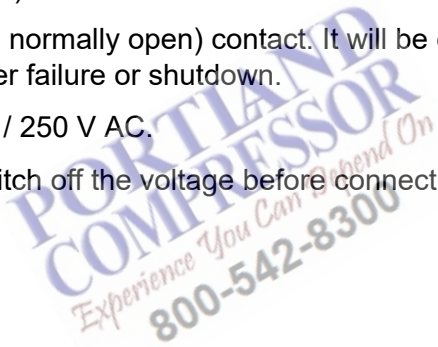

9.4 Pictographs

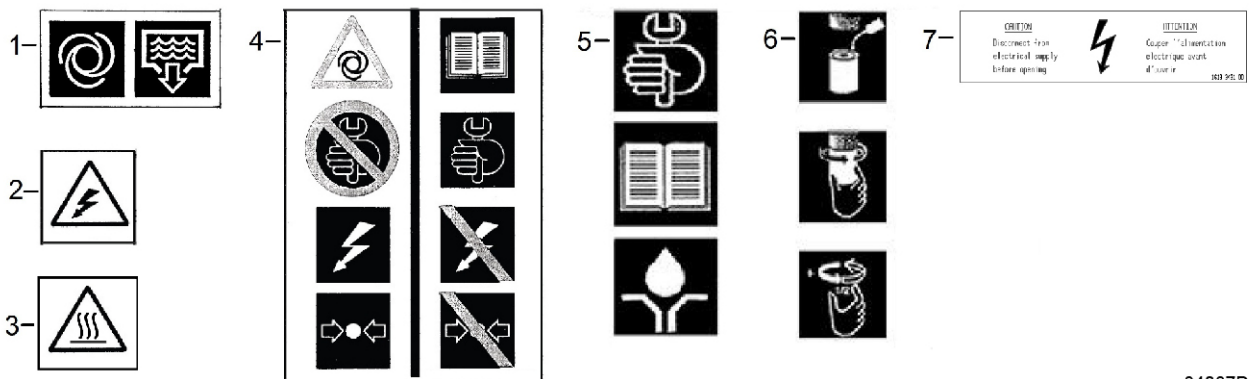

84087D

Reference	Description
1	Automatic condensate drain outlet
2	Warning: voltage
3	Warning: hot surface
4	Warning: do not work on the compressor when the power is on and the compressor is pressurized. Instead, read the manual, disconnect the power and depressurize the compressor before working on it.

Reference	Description
5	Consult the instruction book before carrying out maintenance or lubricating.
6	Lightly oil the gasket of oil filter, screw it on and tighten by hand (approximately half a turn).

On the receiver of receiver mounted compressors, the following label is present:

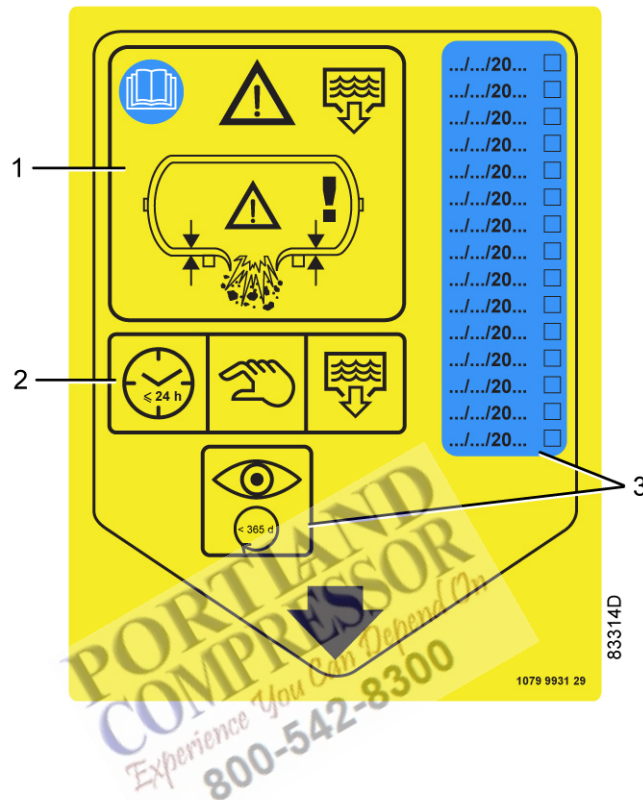

WARNING



1. Read the instruction book. Drain the condensate to reduce the risk of corrosion.
2. Drain the vessel daily by opening the manual drain valve.
3. Inspect the vessel wall thickness yearly and note down the inspection date.

10 Energy recovery

10.1 Energy recovery (ER) unit

Description

A large part of the energy required for any compression process is transformed into heat. The major part of the compression heat is dissipated through the oil system. The energy recovery (ER) systems are designed to recover most of this heat by transforming it into warm or hot water without any adverse effects on compressor performance. The water can be used for diverse applications.

Components

The energy recovery (ER) system is completely integrated and comprises the following:

- Stainless steel oil/water heat exchanger
- Thermostatic by-pass valve for energy recovery heat exchanger(s) (BV2)
- Two temperature sensors for water inlet and outlet control (3 and 4)
- The necessary bolts, pipes, etc.
- Pressure relieve valve with pressure setting of 10 bar
- Oil drain valve

Energy Recovery (ER) unit

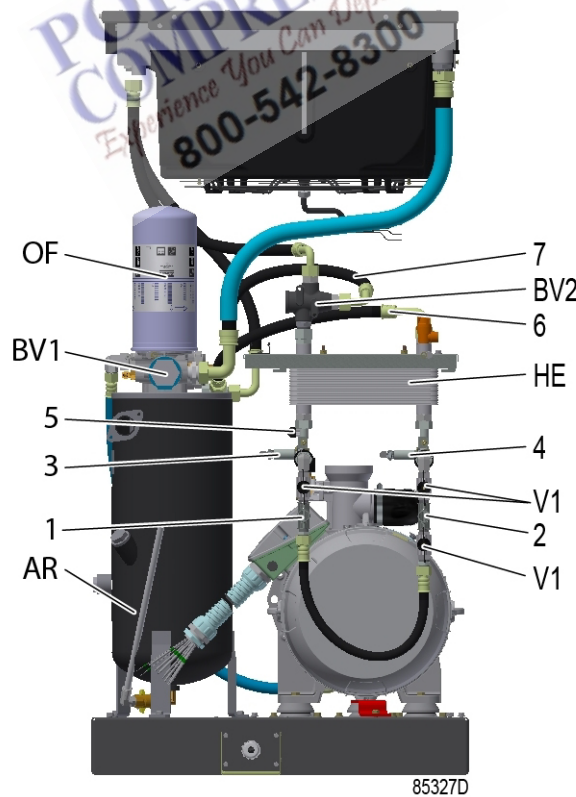

Figure 24: Main components of the energy recovery (ER) unit (typical installation)

Reference	Description
1	Water inlet pipe
2	Water outlet pipe
3	Temperature sensor, water inlet pipe
4	Temperature sensor, water outlet pipe
5	Oil drain valve
6	Oil line from compressor oil separator vessel to ER unit
7	Oil line from ER unit to oil filter housing
BV2	Location of heat exchanger by-pass valve (BV2)
HE	Heat exchanger
V1	Selector valve
AR	Oil separator vessel
OF	Oil filter housing
BV1	Location of oil cooler bypass valve (BV1)

Field installation

The main components are assembled ex-factory as a compact unit which fits inside the bodywork of the compressor. Consult your supplier for installing and connecting the energy recovery (ER) unit.

10.2 Energy recovery (ER) systems

General

The energy recovery (ER) systems can be applied as low temperature rise/high water flow systems or as high temperature rise/low water flow systems.

Low temperature rise/high water flow systems

For this type of application, the temperature difference between the water in the energy recovery (ER) system and the compressor oil is low. As a consequence, a high water flow is needed for maximum energy recovery (ER).

Example: The heated water is used to keep another medium at a moderately high temperature in a closed circuit, e.g. central heating.

High temperature rise/low water flow systems

For this type of application, a high water temperature rise in the energy recovery (ER) system is obtained, which consequently brings on a low flow rate.

Example: An open circuit where cold water from a main supply is heated by the energy recovery (ER) system for use in a factory, e.g. pre-heating of boiler feed water.

Recovery water flow

For the references, see section *Energy recovery data*.

The recovery water enters the unit at the inlet connection (1). The compression heat is transferred from the compressor oil to the water in the heat exchanger (HE). The water leaves the heat exchanger (HE) via the outlet connection (2).

Water requirements for closed water circuits

The use of a closed water circuit minimizes supplementary water requirements. Therefore, the use of soft or even demineralized water is economically feasible and eliminates the problem of scale deposits. Although the heat exchanger is made of stainless steel, the water circuit connected to the compressor may require corrosion inhibitors.

Consult section *Cooling water requirements* to minimize problems due to bad water quality. If in doubt, consult Atlas Copco.

Add an anti-freeze product such as ethylene-glycol to the water in proportion to the expected temperature to avoid freezing.

Water requirements for open water circuits

In open, non-recirculating water circuits, major problems that are usually encountered are related to deposit control, corrosion control, and microbiological growth control. To minimize these problems, the water that is being used should meet a number of requirements.

See section *Cooling water requirements*. If in doubt, consult Atlas Copco.

10.3 Energy recovery (ER) operation

Description

The compressor oil flow is controlled by two thermostatic valves (BV1 and BV2), ensuring reliable compressor operation and optimum energy recovery (ER).

Bypass valve (BV1) is integrated in the oil filter housing of the compressor and controls the oil flow to the heat exchanger (HE) and the main oil cooler (Co) of the compressor. Bypass valve (BV2) controls the oil flow through the oil/water heat exchanger (HE) of the energy recovery (ER) unit. Both valves consist of an insert (thermostat) mounted in a housing.

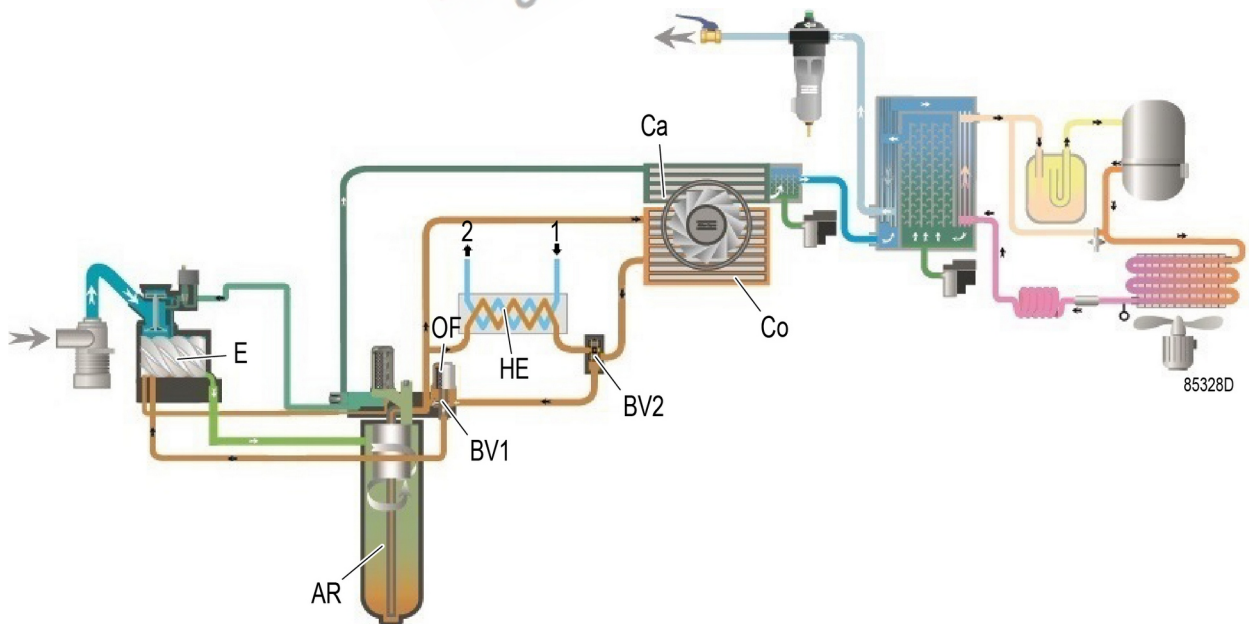

Figure 25: Flow diagram of compressor with energy recovery (ER) system

Reference	Description	Reference	Description
BV2	Thermostatic bypass valve of ER unit	OF	Oil filter
HE	Oil/water heat exchanger (ER unit)	AR	Oil separator vessel
E	Compressor element	BV1	Thermostatic bypass valve in oil filter housing
Co	Oil cooler (compressor)	Ca	Aftercooler (compressor)
1	Water inlet	2	Water outlet

BV1 starts closing the bypass line over the oil cooling circuit at the lower limit of its temperature range. At the upper limit of its temperature range, the bypass line is completely closed and all the oil flows through the oil cooling circuit.

BV2 starts closing the bypass line over the ER heat exchanger (HE) at the lower limit of its temperature range. At the upper limit of its temperature range, the bypass line is completely closed and all the oil flows through the main oil cooler (Co).

Bypass valve BV1 starts opening at 71 °C (160 °F) and is completely open at 85 °C (185 °F).

Bypass valve BV2 starts opening at 75 °C (167 °F) and is completely open at 90 °C (194 °F).

The energy recovery (ER) system can be provided with bypass valves on the water side.

When the ball valves are in position (A), as shown on the ER label, the ER unit is integrated in the water circuit and will recover energy.

When the ball valves are in position (B), the heat exchanger (HE) is bypassed and no energy will be recovered.

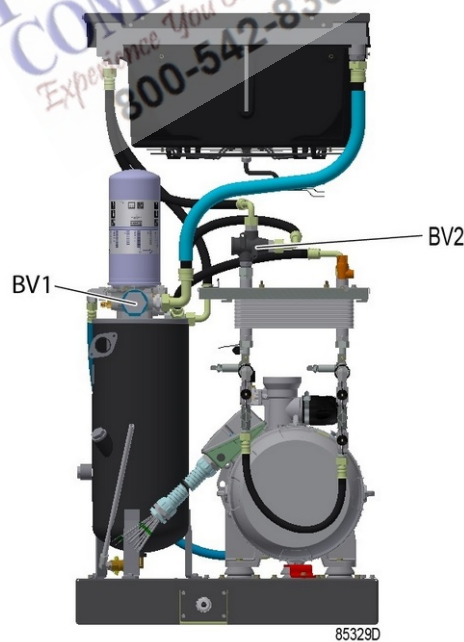

Figure 26: Position of bypass ball valves

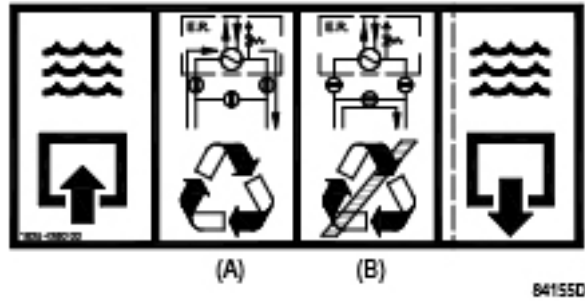

Figure 27: Energy recovery (ER) label



IMPORTANT

It is NOT allowed to use the ball valves at an in-between position!

Energy recovery (ER) system in use (see drawing)

Bypass valves in position (A): the heat exchanger (HE) is integrated in the water side of the energy recovery unit.

- Compressor start-up

When the compressor is started up from cold, the oil temperature will be low. Bypass valve (BV1) shuts off the oil supply to the oil cooling system to prevent the compressor oil from being cooled. The oil flows from the oil separator vessel (AR) through the oil filter(s) (OF) back to the compressor element (E).

All energy input is used to rapidly warm up the compressor oil. No energy is recovered.

- Maximum energy recovery

As soon as the oil temperature reaches the set point (opening temperature) of the bypass valve (BV1), the valve starts closing off the bypass over the oil cooling system, gradually allowing the oil to flow through the heat exchanger (HE). As the oil temperature rises to approx. 75 °C (167 °F), all the oil passes through the cooling system. The exchange of heat between the compressor oil and the heat recovery water is maximum. The oil from the heat exchanger outlet flows via the oil filter (OF), the compressor element (E) and the separator (AR) back to the inlet of the heat exchanger (HE).

Bypass valve (BV2) bypasses the main oil cooler (Co) as long as the oil temperature remains below its set point.

Operation principle at different loads:

- Low consumption of recovered energy

The temperature of the oil leaving the heat exchanger (HE) rises. When the temperature rises above its set point, the oil cooler bypass valve (BV2) will gradually allow the oil to be cooled in the oil cooler (Co).

- Recovery water flow too high/temperature too low

In this case, the bypass valve (BV1) will open the bypass line allowing oil from the heat exchanger (HE) to be mixed with oil from separator (AR). Energy is transferred from the compressor oil to the water, but at a relatively low temperature level.

Energy recovery (ER) system not in use

Bypass valves in position (B): the heat exchanger (HE) is bypassed in the water side of the energy recovery unit.

The oil circuit is the same as without installation of the energy recovery (ER) system.

No energy is recovered.

This situation should be considered as exceptional, e.g. in case of maintenance of the energy recovery (ER) system or when no energy is required for a long period.

Stopping the unit for a long period

In case of an open water system and/or if freezing temperatures can be expected, isolate the compressor water system and blow it through with compressed air.

10.4 Energy recovery (ER) maintenance

Compressor oil

For references used consult section *Energy recovery (ER) unit*.

Oil change:

1. Run the unit until warm. Stop the unit, switch off the isolating switch and close the air outlet valve of the compressor.
2. Depressurize the compressor and drain the oil by opening the drain valve. Also drain the oil from the heat exchanger by opening the drain valve on the heat exchanger (HE). Close the valve after draining.
3. Resume the oil change as described in section *Oil and Filter Change* in this book.

Thermostatic bypass valves

Change the thermostat of the energy recovery (ER) system at the same interval as the thermostat of the unit.

Heat exchanger (HE)

If the temperature rise over the energy recovery (ER) system declines over a period of time with the same basic working conditions, the heat exchanger should be inspected. To clean the oil side, soak the heat exchanger in a degreasing solution. To remove scale formation in the water compartment, a proper descaling process should be applied. Consult your supplier.

10.5 Cooling water requirements

General



NOTE

Cooling water needs to fulfill certain requirements in order to avoid problems of scaling, fouling, corrosion or bacterial growth.

In open circuit cooling towers, protective measures must be taken to avoid the growth of harmful bacteria such as legionella pneumophila when there is a risk of inhalation of the water droplets.

No general recommendation can encompass the effects of all combinations of the various compounds, solids and gases typically found in cooling water in interaction with different materials. Therefore the recommendations formulated in our Cooling Water Specifications are a general guide line for acceptable coolant quality. However, where strict limits apply, a statement is made in the specification.

The water requirements refer to untreated water. When water is treated, some parameters will change. Water treatments should be carried out by a specialized water treatment company, taking the responsibility for the performance of the treated cooling water and the compatibility with the materials in the cooling circuit. This includes not only the selection of the appropriate additives, but also the correct application, monitoring of concentrations and properties, prevention of sludge formation and maintenance of the system. This applies also to treatment with antifreeze products. They must be provided with suitable stabilizers and inhibitors. Specifications are also depending on the type of cooling circuit (open, once through / recirculating with tower / closed) and on the application (standard – max 65 °C cooling water temperature at the outlet) or Energy Recovery (water temperature up to 95 °C).

In case the water is not in line with the recommended values or if there is any doubt, consult the manufacturer.

Cooling water parameters

1. pH

The effect of pH is already included in the Ryznar Stability Index (RSI - see item 4 below), but also the pH itself is subject to limitations:

Type of cooling system	Materials	pH	
		Standard	Energy recovery
Single pass	Containing copper	6.8 - 9.3	6.8 - 9.3
	Stainless steel with carbon steel and / or cast iron	6.8 - 9.3	6.8 - 9.3
	Stainless steel only	6 - 9.3	6 - 9.3
Recirculating (with tower)	Containing copper	6.8 - 9.3	not applicable
	Stainless steel with carbon steel and / or cast iron	6.8 - 9.3	
	Stainless steel only	6 - 9.3	
Closed loop	Containing copper	7.5 - 9.3	7.5 - 9.3
	Stainless steel with carbon steel and / or cast iron	7.5 - 9.3	7.5 - 9.3
	Stainless steel only	6 - 9.3	6 - 9.3

The values in **bold** are rejection limits.

When the system contains Zn or Al, the pH must be < 8.5.

2. Total dissolved solids (TDS) and conductivity

The conductivity is expressed in µS/cm, the TDS in ppm.

Both parameters are related with each other. The conductivity is convenient for quick monitoring of general water quality, but the TDS is required for calculating the RSI. If only one of both parameters is measured, an estimation can be obtained by using a theoretical conversion factor (0.67):

$$\text{TDS} = \text{conductivity} \times 0.67$$

3. Hardness

Different types of hardness together with the pH and the alkalinity of the water they determine the equilibrium situation of the water, specified by the RSI.

In addition, the calcium hardness must be limited to:

Type of cooling system	Ca (ppm Ca CO ₃)	
	Standard	Energy recovery
Single pass	< 500	< 2
Recirculating (with tower)	< 500	not applicable
Closed loop	< 1000	< 50

4. The Ryznar Stability Index (RSI)

The Ryznar Stability Index is a parameter for predicting whether water will tend to dissolve or precipitate calcium carbonate. The adhesion of scaling depositions and their effect are different on different materials, but the equilibrium of the water (scaling or corrosive) is only determined by its actual pH value and by the saturation pH value (pH_s). The saturation pH value is determined by the relationship between the calcium hardness, the total alkalinity, the total solids concentration and the temperature.

The Ryznar Stability Index is calculated as follows:

$$\text{RSI} = 2 \cdot \text{pH}_s - \text{pH}$$

in which

- pH = measured pH (at room temp) of the water sample
- pH_s = pH at saturation

pH_s is calculated from:

$$\text{pH}_s = (9.3 + A + B) - (C + D)$$

in which

- A : depends on the total solids concentration
- B : depends on the water temperature at the outlet of the heat exchanger
- C : depends on the calcium hardness (CaCO₃)
- D : depends on the HCO₃⁻ concentration or M-alkalinity

The values of A, B, C and D can be found in below table:

Total dissolved solids (mg/l)	A	Temperature (°C)	B	Ca hardness (ppm CaCO ₃)	C	M-Alkalinity (ppm CaCO ₃)	D
< 30	0.1	0 - 1	2.3	9 - 11	0.6	10 - 11	1.0
30 - 320	0.2	2 - 6	2.2	12 - 14	0.7	12 - 14	1.1
> 320	0.3	7 - 11	2.1	15 - 17	0.8	15 - 17	1.2

Total dissolved solids (mg/l)	A	Temperature (°C)	B	Ca hardness (ppm CaCO ₃)	C	M-Alkalinity (ppm CaCO ₃)	D
		12 - 16	2.0	18 - 22	0.9	18 - 22	1.3
		17 - 22	1.9	23 - 28	1.0	23 - 28	1.4
		23 - 27	1.8	29 - 35	1.1	29 - 35	1.5
		28 - 32	1.7	36 - 44	1.2	36 - 44	1.6
		33 - 38	1.6	45 - 56	1.3	45 - 56	1.7
		39 - 43	1.5	57 - 70	1.4	57 - 70	1.8
		44 - 49	1.4	71 - 89	1.5	71 - 89	1.9
		50 - 55	1.3	90 - 112	1.6	90 - 112	2.0
		56 - 61	1.2	113 - 141	1.7	113 - 141	2.1
		62 - 67	1.1	142 - 177	1.8	142 - 177	2.2
		68 - 73	1.0	178 - 223	1.9	178 - 223	2.3
		74 - 79	0.9	224 - 281	2.0	224 - 281	2.4
		80 - 85	0.8	282 - 355	2.1	282 - 355	2.5
		86 - 91	0.7	356 - 446	2.2	356 - 446	2.6
		92 - 95	0.6	447 - 563	2.3	447 - 563	2.7
				564 - 707	2.4	564 - 707	2.8
				708 - 892	2.5	708 - 892	2.9
				893 - 1000	2.6	893 - 1000	3.0

Interpretation of the values obtained:

- RSI < 6: boiler scale formation
- 6 < RSI < 7: neutral water
- RSI > 7: corrosive water



NOTE

As a general rule, the RSI index should be between 5.6 and 7.5. If that is not the case, contact a specialist.

5. Free chlorine (Cl₂)

Disinfecting with chlorine is **not done in closed systems, neither in energy recovery (ER) systems.**

A continuous level of 0.5 ppm should not be exceeded. For shock treatments, a maximum limit of 2 ppm for maximum 30 minutes/day applies.

6. Chlorides (Cl⁻)

Chloride ions will create pitting corrosion on stainless steel. Their concentration should be limited, depending from the RSI value.

	RSI < 5.5	5.6 < RSI < 6.2	6.3 < RSI < 6.8	6.9 < RSI < 7.5	7.6 < RSI
Cl ⁻ (ppm)	200	350	500	350	200

For energy recovery (ER) systems, the limit is 100 ppm.

7. Sulphates (SO₄²⁻)

Type of cooling system	Sulphate (ppm)	
	Standard	Energy recovery
Single pass	< 1000	< 200
Recirculating (with tower)	< 1000	not applicable
Closed loop	< 400	< 200

8. Iron and Manganese

Type of cooling system	Dissolved iron (ppm)		Dissolved manganese (ppm)	
	Standard	Energy recovery	Standard	Energy recovery
Single pass	< 1	< 0.2	< 0.2	< 0.05
Recirculating (with tower)	< 1	not applicable	< 0.2	not applicable
Closed loop	< 1	< 0.2	< 0.2	< 0.05

The values in **bold** are rejection limits.

9. Copper

Type of cooling system	Copper (ppm)	
	Standard	Energy recovery
Single pass	< 1	< 0.2
Recirculating (with tower)	< 1	not applicable
Closed loop	< 1	< 0.2

10. Ammonium

The limit of **0.5 ppm** is a rejection limit.

The limitation only applies for copper containing systems.

11. Suspended solids

Large particles (size > 10 µm) should not be present as they can be filtered out.

Small particles (< 0.5 µm) are not taken into account.

For particles between 0.5 µm and 10 µm, the following limits apply:

Type of cooling system	Suspended solids (ppm)	
	Standard	Energy recovery
Single pass	< 10	< 1
Recirculating (with tower)	< 10	not applicable
Closed loop	< 10	< 1

12. Oil or grease

< **1 ppm** (rejection value)

13. Biology

If biology is present, it must be aerobic. Anaerobic biology (in closed systems) must be avoided.

Type of cooling system	Biology (CFU/ml)	
	Standard	Energy recovery
Single pass	< 10 ⁵ / < 10 ⁷	< 10 ³ / < 10 ⁵

Type of cooling system	Biology (CFU/ml)	
	Standard	Energy recovery
Recirculating (with tower)	< 10 ⁵ / < 10⁷	not applicable
Closed loop	< 10 ³ / < 10⁵	< 10 ³ / < 10⁵

The table shows the recommended values. The values in **bold** are rejection limits.

NOTE

If additives are used in the cooling water, take into account that the cooling capacity will change.



$$\Delta m = ((C_{pw} - C_{pa}) * X) / (C_{pw} *(1-X) + X*C_{pa}) * 100 \%$$

with,

Δm: change of mass flow of the coolant

C_{pw}: specific heat capacity of water

C_{pa}: specific heat capacity of the additives

X: the percentage of additives

10.6 Energy recovery (ER) data

Reference conditions

See section *Reference conditions and limitations*.

Effective working pressure

See section *Compressor data* for the normal working pressure.

Maximum allowed pressure of the heat exchanger

Characteristic	Unit	Data
Oil side	bar	15
	psi	217
Water side	bar	10
	psi	145

Reading settings

In addition to other data, the following temperatures can be read on the controller display:

For air-cooled units:

- The water inlet temperature of the energy recovery (ER) system
- The water outlet temperature of the energy recovery (ER) system

Modifying settings

If the programmed warning settings for the water temperatures are exceeded, a warning indication is shown on the controller:

Temperature input	Unit	Minimum setting	Nominal setting	Maximum setting
Water inlet temperature of energy recovery	°C	0	50	99
Water inlet temperature of energy recovery	°F	32	122	210
Energy recovery water outlet temperature	°C	0	60	99
Energy recovery water outlet temperature	°F	32	60	210

To modify a setting, consult the relevant section in the description of the controller.

Recoverable energy

The recoverable energy can be calculated from:

$$\text{RECOVERED ENERGY (kW)} = 4.2 \times \text{water flow (l/s)} \times \text{water temperature rise (°C)}$$

In the tables below, typical examples are given.

Data for low temperature rise/high water flow systems

Parameter	Unit	GA 15	GA 18	GA 22	GA 26	GA 30
Recoverable energy	kW	13.2	15.8	19.4	22.9	26.4
Recoverable energy	hp	18	21.5	26.3	31.1	35.4
Pressure drop	mbar	19	26	35	47	62
Pressure drop	in WC	8	10	14	19	25
Temperature at inlet	°C	50	50	50	50	50
Temperature at inlet	°F	122	122	122	122	122
Temperature at outlet	°C	60	60	60	60	60
Temperature at outlet	°F	140	140	140	140	140

Data for high temperature rise/low water flow systems

Parameter	Unit	GA 15	GA 18	GA 22	GA 26	GA 30
Recoverable energy	kW	13.2	15.8	19.4	22.9	26.4
Recoverable energy	hp	18	21.5	26.3	31.1	35.4
Pressure drop	mbar	< 10	< 10	< 10	< 10	< 10
Pressure drop	in WC	< 4	< 4	< 4	< 4	< 4
Temperature at inlet	°C	20	20	20	20	20
Temperature at inlet	°F	68	68	68	68	68
Temperature at outlet	°C	60	60	60	60	60
Temperature at outlet	°F	140	140	140	140	140

11 Operating instructions

11.1 Initial start up

Procedure



WARNING

Always apply all relevant safety precautions.

1. Consult sections *Installation proposal*, *Electric cable size* and *Settings of overload relay and fuses*.
2. Check that the electrical connections correspond to the applicable codes and that all wires are clamped tight to their terminals.

The installation must be earthed and protected against short circuits by fuses of the inert type in all phases. An isolating switch must be installed near the compressor.

3. Check transformer (T1) for correct connection.

For Full-Feature units except for voltages 230 V and 400 V + N: check the dryer transformer (T2) for correct connection.

Check the settings of drive motor overload relay (F21).

Check that the motor overload relay is set for manual resetting.

4. Check the oil level. Add oil if necessary (see section *Checking the oil level*).
5. **Provide labels, warning the operator that:**
 - The compressor is automatically controlled and may restart automatically.
 - The compressor may automatically restart after voltage failure (if the function is activated - consult Atlas Copco).

6. The compressors are equipped with a phase sequence relay to protect the compressor from running in the wrong direction.

Switch on the voltage and start the compressor.

If the compressor fails to start, check the display. If the display shows the pictograph for motor overload, check the phase sequence relay.

If the rotation direction of the drive motor is incorrect or if the motor doesn't start, open the isolating switch and reverse two incoming electric lines.

Incorrect rotation direction of the motor may cause damage to the compressor element.

7. Check the programmed settings.
8. Start and run the compressor for a few minutes. Check that the compressor operates normally.

11.2 Starting

Procedure

NOTE



Check the oil level, top up if necessary. See section *Initial start up*.

For the position of the air outlet valve and the drain connections, see section *Introduction*.

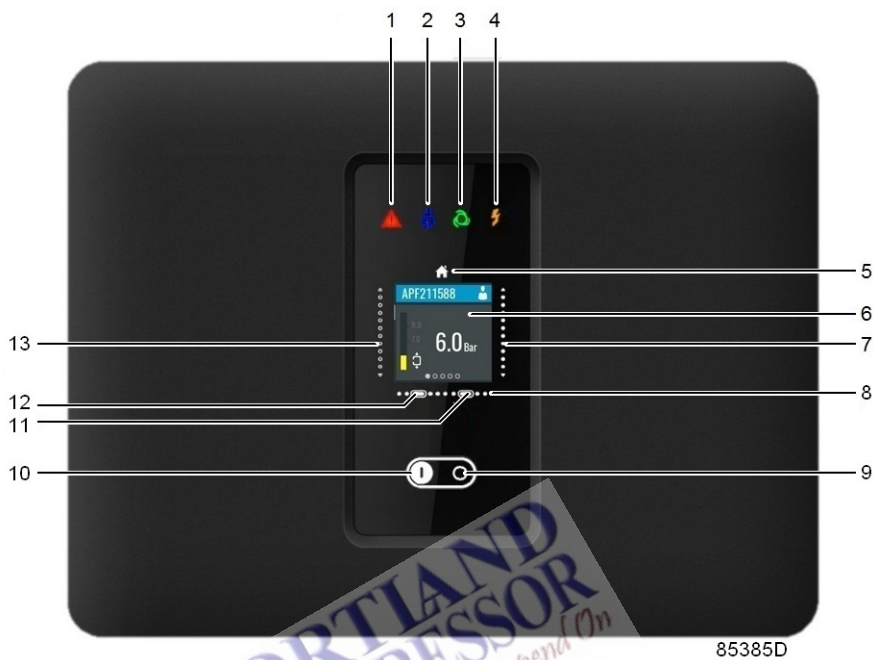

Figure 28: Control panel Elektronikon™ Swipe

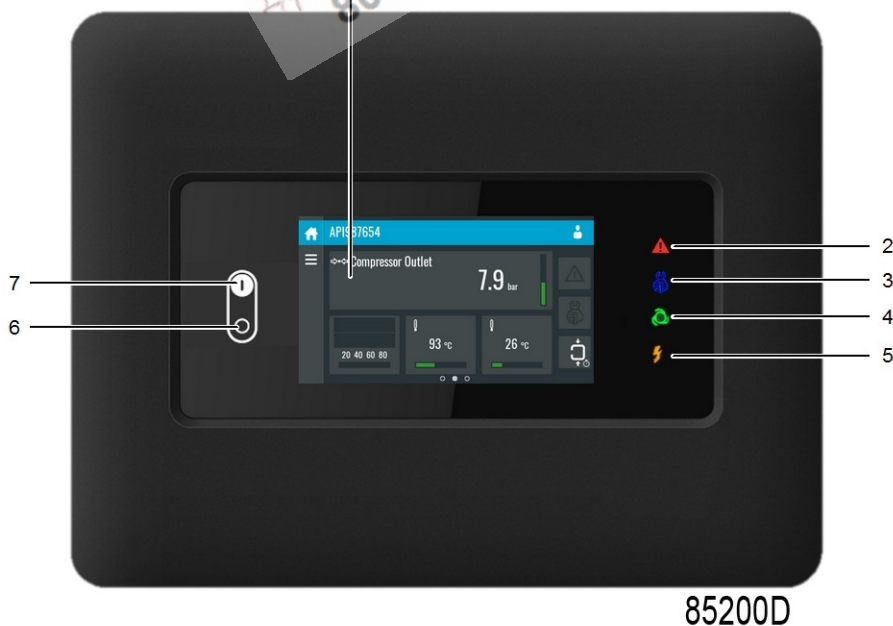

Figure 29: Control panel Elektronikon™ Touch

1. Open the air outlet valve.

2. Switch on the voltage. Check that voltage on LED lights up.
3. Press start button on the control panel. The compressor starts running and the automatic operation LED lights up.

11.3 During operation

WARNING



The operator must apply all relevant safety precautions. Also consult section *Problem solving*.

NOTE



Removing the front panel (service panel) during operation will lead to an automatic shutdown of the unit after a certain time depending of the compressor version.

NOTE



Keep the doors closed during operation.

DANGER



When the motors are stopped and LED (8) (automatic operation) is alight, the motors may start automatically.

Checking the display

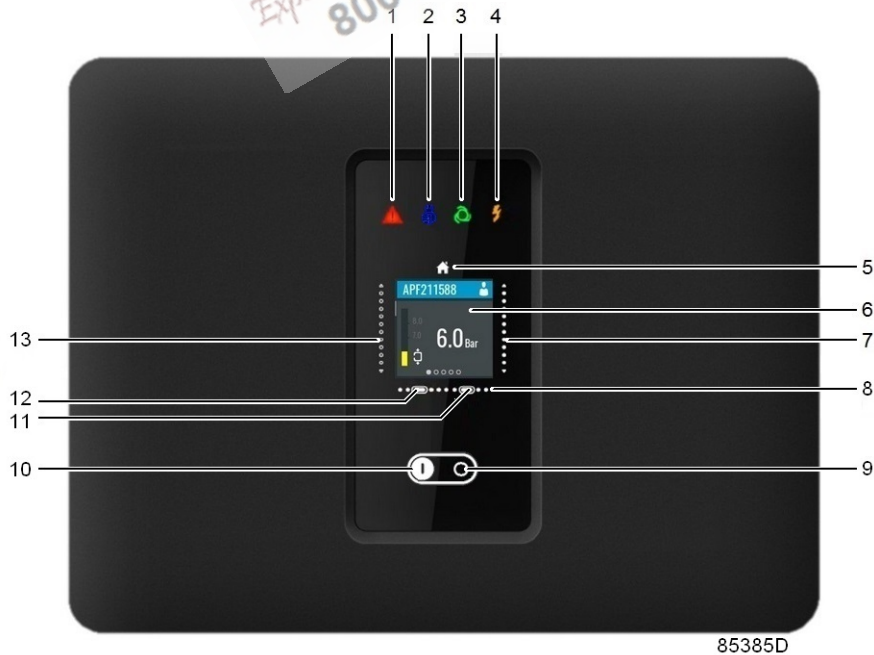

Figure 30: Control panel Elektronikon™ Swipe

Check the display (6) regularly for readings and messages. The display normally shows the compressor outlet pressure, while the status of the compressor is indicated by pictographs. Remedy the trouble if the alarm LED (1) is lit or flashes.

The display (6) will show a service message if a service plan interval has been exceeded or if a service level for a monitored component has been exceeded. The service LED is on. Carry out the service actions of the indicated plans or replace the component and reset the relevant timer.

Checking the display

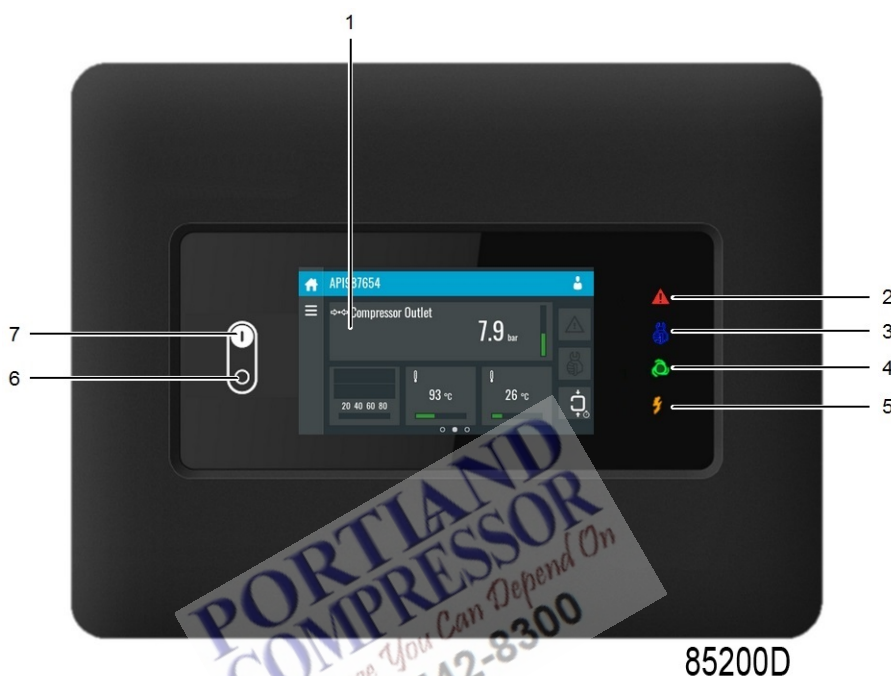

Figure 31: Control panel Elektronikon™ Touch

Check the display (1) regularly for readings and messages. The display normally shows the compressor outlet pressure, while the status of the compressor is indicated by pictographs. Remedy the trouble if alarm LED (2) is lit or flashes.

The display (1) will show a service message if a service plan interval has been exceeded or if a service level for a monitored component has been exceeded. The service LED is on. Carry out the service actions of the indicated plans or replace the component and reset the relevant timer.

Checking the oil level

WARNING



When the automatic operation LED (8) is lit, the regulator is automatically controlling the compressor, i.e. loading, unloading, stopping of the motors and restarting!

Regularly check the oil level and top up if necessary.

- Switch off the machine with push button (9): this way the machine stops after 30 seconds of idle running.
- Disconnect the power supply by means of the disconnecter switch on the compressor and on the dryer if fitted.

- Wait about 5 minutes for the foam in the oil collector to abate.
- If the oil level is not visible in the sight glass (GI), press the emergency stop button (S3), close the air outlet valve and open (if provided) the manual condensate drains.
- Next, depressurize the oil system by unscrewing the oil filler plug (FC) one turn and wait a few minutes. Remove the plug and top up oil until the sight glass is full. Fit and tighten the filler plug.

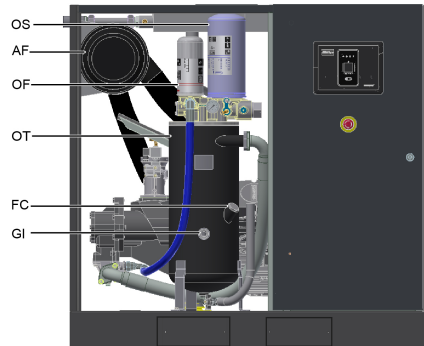

Figure 32: Position of oil level sight glass

Air filter

Especially if the compressor is installed in a dusty environment, inspect the air filter element regularly. Replace when necessary. See also *Preventive maintenance schedule* for periodic replacement instructions.

Drains

Regularly check that condensate is discharged during operation. See section *Preventive maintenance schedule*. The amount of condensate depends on environmental and working conditions.

11.4 Stopping

Elektronikon™ controller

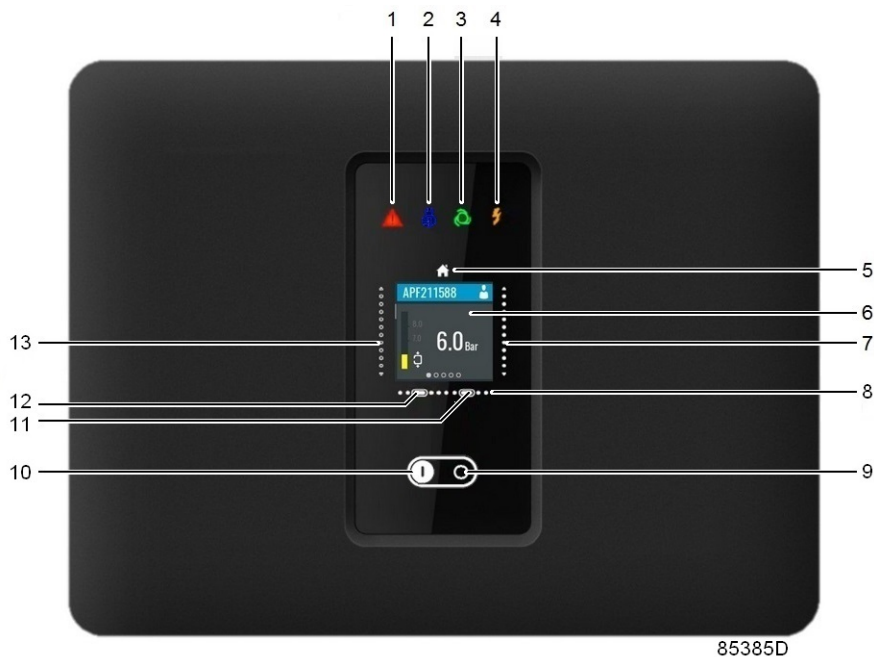

Figure 33: Control panel Elektronikon™ Swipe



Figure 34: Control panel Elektronikon™ Touch

Procedure

1. If Remote Control or LAN Control is selected, change the setting to Local Control as described in the Machine settings menu.
2. Press stop button (9). The automatic operation LED (8) goes out and the compressor stops after a programmed number of seconds of unloaded operation (programmed stop time).
3. **To stop the compressor in the event of an emergency**, press the emergency stop button (10). Alarm LED flashes (7).

Do not use the emergency stop button (10) for normal stopping!

4. Close the air outlet valve (AV), see section *Introduction*.

11.5 Taking out of operation



WARNING

The operator must apply all relevant safety precautions.

Procedure

1. Stop the compressor and close the air outlet valve.
2. Open the manual condensate drain (if provided).
3. Switch off the voltage and disconnect the compressor from the mains.
4. Unscrew the oil filler plug only one turn to permit any pressure in the system to escape.
5. Shut off and depressurize the part of the air net which is connected to the outlet valve. Disconnect the compressor air outlet pipe from the air net.
6. Drain the oil.
7. Drain the condensate circuit and disconnect the condensate piping from the condensate net.

**PORTLAND
COMPRESSOR**
Experience You Can Depend On
800-542-8300

12 Maintenance

12.1 Preventive maintenance schedule

Control panel

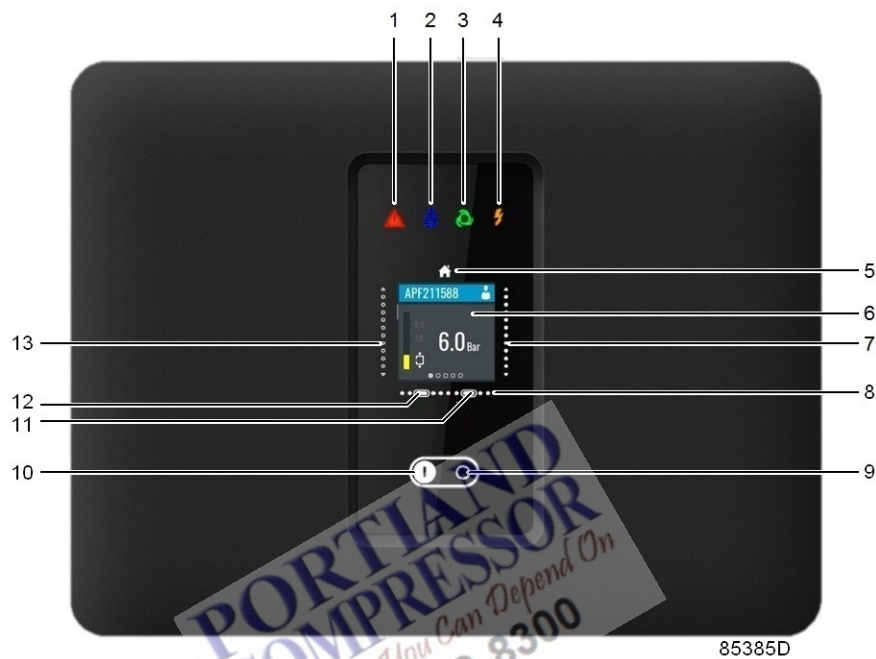

Figure 35: Control panel Elektronikon™ Swipe

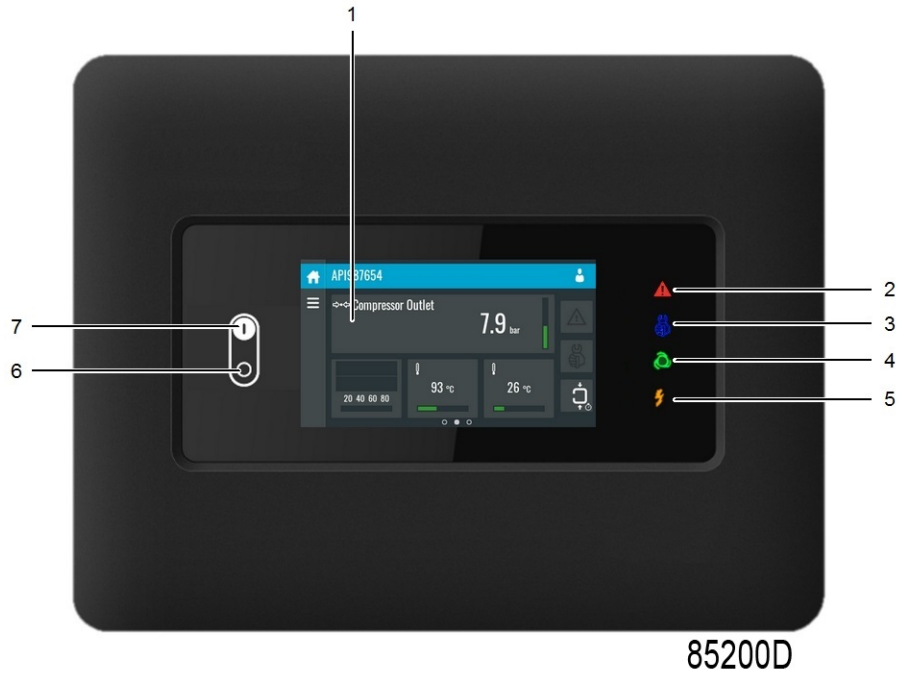

Figure 36: Control panel Elektronikon™ Touch

WARNING

Before carrying out any maintenance, repair work or adjustments, proceed as follows:



- Stop the compressor.
- Press the emergency stop button.
- Switch off the voltage.
- Close the air outlet valve and open, if provided, the manual condensate drain valves.
- Depressurize the compressor.

For detailed instructions, see section *Problem solving*.

The operator must apply all relevant safety precautions. Failure to adhere to these maintenance recommendations can result in damage (fire, explosion) or injury.

Warranty - Product Liability

Use only authorized parts. Any damage or malfunction caused by the use of unauthorized parts is not covered by Warranty or Product Liability.

Service kits

For overhauling or carrying out preventive maintenance, service kits are available (see section *Service kits*).

Service contracts

Atlas Copco offers several types of service contracts, relieving you of all preventive maintenance work. Consult your Atlas Copco Customer Center.

General

When servicing, replace all removed gaskets, O-rings and washers.

Intervals

The local Atlas Copco Customer Center may overrule the maintenance schedule, especially the service intervals, depending on the environmental and working conditions of the compressor.

The longer interval checks must also include the shorter interval checks.

Preventive maintenance schedule

Period	Action
Daily	Check oil level. Check readings on display. Check that condensate is discharged during loading. Drain condensate. Check the service indicator on the DD and PD filters (if provided).
3-monthly (1)	Check coolers, clean if necessary. Remove the air filter element. Clean using an air jet and inspect. Replace damaged or heavily contaminated elements. Check the filter element of the electrical cabinet (where applicable). Replace if necessary On Full-Feature units: Check condenser of dryer and clean if necessary. Check and clean the filter mesh.
Yearly	Replace DD and PD filters or whenever the pressure indicator points red (if provided). Yearly inspect the air receiver. Minimum wall thickness as specified in the instruction book must be respected. Local regulations remain applicable if they are more strict.

Table 1: Daily and 3-monthly check list

(1): More frequently when operating in a dusty atmosphere.

Running hours	Operation
4000 (1)	If Roto-Foodgrade Fluid is used, replace oil and oil filter. If Roto-Inject Fluid Ndurance is used, replace oil and oil filter. Check the electrical connections. Tighten if required according to values indicated on service diagram. Replace the oil separator element. Replace the air filter element. Clean coolers. Check pressure and temperature readings. Carry out a LED/display test. Check for leakages. Check the condition of the air intake hose of the air filter. On Full-Feature units: clean condenser of dryer and apply the wear kit. Test temperature shutdown function.
8000 (2)	If Roto Synthetic Fluid Xtend Duty is used, replace the oil and the oil filter. Replace the non return valve of the scavenge line. Replace the minimum pressure valve and the thermostatic valve. Remove carefully. Apply the wear kit. Apply the unloading valve kit. Test safety valve.

Table 2: Preventive Maintenance schedule programmed in the Elektronikon™

(1): or yearly, whichever comes first

(2): or every 2 years, whichever comes first

The indicated oil exchange intervals are valid for standard operating conditions (see section *Reference conditions and limitations*) and nominal operating pressure (see section *Compressor data*). Exposure of the compressor to external pollutants, operation at high humidity combined with low duty cycles or operation at higher temperatures may require a shorter oil exchange interval. Contact Atlas Copco if in doubt.

Exchange interval for Roto-Inject Fluid Ndurance

Ambient temperature	Element outlet temperature	Exchange interval *	Maximum time interval *
up to 25 °C	up to 90 °C	4000 hours	1 year
from 25 °C up to 35 °C	from 90 °C up to 100 °C	3000 hours	1 year
more than 35 °C	more than 100 °C	2000 hours	1 year

Exchange interval for Roto Synthetic Fluid Xtend Duty

Ambient temperature	Element outlet temperature	Exchange interval	Maximum time interval
up to 40 °C	up to 110 °C	8000 hours	2 year
more than 40°C	more than 110 °C	6000 hours	2 year

Ambient temperature	Element outlet temperature	Exchange interval	Maximum time interval
up to 40 °C	up to 110 °C	8000 hours	2 year
more than 40°C	more than 110 °C	6000 hours	2 year

Exchange interval for Roto-Foodgrade Fluid

Ambient temperature	Element outlet temperature	Exchange interval	Maximum time interval
up to 25 °C	up to 90 °C	4000 hours	1 year
from 25 °C up to 35 °C	from 90 °C up to 100 °C	3000 hours	1 year
more than 35 °C	more than 100 °C	2000 hours	1 year

Ambient temperature	Element outlet temperature	Exchange interval	Maximum time interval
up to 25 °C	up to 90 °C	4000 hours	1 year
from 25 °C up to 35 °C	from 90 °C up to 100 °C	3000 hours	1 year
more than 35 °C	more than 100 °C	2000 hours	1 year

IMPORTANT



- Always consult Atlas Copco if a timer setting has to be changed.
- For the change interval of oil and oil filter in extreme conditions of temperature, humidity or cooling air, consult your Atlas Copco Customer Center.
- Any leakage should be attended to immediately. Damaged hoses or flexible joints must be replaced.

- Extending the use of the oil, exceeding the exchange intervals stated above may create a risk for fire hazard.

12.2 Oil specifications

In order to achieve the best machine performance and guarantee the reliability, it is required to use genuine Atlas Copco Lubricants. Their tailor made formulation is the result of years of field experience, research and in-house development. Consult the Spare Parts list for part number information.

WARNING



Avoid mixing lubricants of different brands or types as they may not be compatible and the oil mix may have inferior properties. A label, indicating the type of oil filled ex factory, is stuck on the air receiver/oil tank.

Ambient temperature	Humid	Dust	Duty type
Below 30 °C (86 °F)	No	No	Mild
Below 30 °C (86 °F)	Yes	No	Mild
Below 30 °C (86 °F)	No	Yes	Mild
Below 30 °C (86 °F)	Yes	Yes	Demanding
Between 30 °C (86 °F) and 40 °C (104 °F)	No	No	Demanding
Between 30 °C (86 °F) and 40 °C (104 °F)	Yes	No	Demanding
Between 30 °C (86 °F) and 40 °C (104 °F)	No	Yes	Demanding
Between 30 °C (86 °F) and 40 °C (104 °F)	Yes	Yes	Extreme
Above 40 °C (104 °F)	-	-	Extreme

Table 3: Relation between the operating conditions and the duty type

Roto-Inject Fluid NDURANCE

Atlas Copco's Roto-Inject Fluid NDURANCE is a premium mineral oil based 4000 hours lubricant, specifically developed for use in single stage oil injected screw compressors running in **mild conditions**. Its specific formulation keeps the compressor in excellent condition. Roto-Inject Fluid NDURANCE can be used for compressors operating at ambient temperatures between 0 °C (32 °F) and 40 °C (104 °F). If the compressor is regularly operating in ambient temperatures above 35 °C (95 °F), it is recommended to use Roto Synthetic Fluid ULTRA or Roto Synthetic Fluid XTEND DUTY.

See the table below for recommended oil exchange intervals:

Ambient temperature	Element outlet temperature	Exchange interval	Maximum time interval
up to 30°C (86°F)	up to 95°C (203°F)	4000	1 year
from 30°C (86°F) up to 35°C (95°F) (see note)	from 95°C (203°F) up to 100°C (212°F)	3000	1 year
from 35°C (95°F) up to 40°C (104°F) (see note)	from 100°C (212°F) up to 105°C (221°F)	2000	1 year

Ambient temperature	Element outlet temperature	Exchange interval	Maximum time interval
above 40°C (104°F)	above 105°C (221°F)	use Roto Synthetic Fluid XTEND DUTY	use Roto Synthetic Fluid XTEND DUTY

Note: the presence of dust and/or high humidity may require a shorter exchange interval. Consult Atlas Copco.

Roto Synthetic Fluid ULTRA

Roto Synthetic Fluid ULTRA is a **synthetic oil based 4000 hours lubricant**, specifically developed for use in single stage oil injected screw compressors running in **demanding conditions**. Roto Synthetic Fluid ULTRA can be used for compressors operating at ambient temperatures between 0 °C (32 °F) and 40 °C (104 °F). For more extreme conditions, or when continuously operating at temperatures above 40 °C (104 °F), it is recommended to use Roto Synthetic Fluid XTEND DUTY.

See the table below for recommended oil exchange intervals:

Ambient temperature	Element outlet temperature	Exchange interval	Maximum time interval
up to 35°C (95°F)	up to 100°C (212°F)	6000	2years
from 35°C (95°F) up to 40°C (104°F) (see note)	from 100°C (212°F) up to 105°C (221°F)	4000	2years
from 40°C (104°F) up to 45°C (113°F) (see note)	from 105°C (221°F) up to 110°C (230°F)	2000	2years

Note: the presence of dust and/or high humidity may require a shorter exchange interval. Consult Atlas Copco.

Roto Synthetic Fluid XTEND DUTY

Atlas Copco's Roto Synthetic Fluid XTEND DUTY is a high quality **synthetic 8000 hours lubricant** for oil injected screw compressors which keeps the compressor in excellent condition. Because of its excellent oxidation stability, Roto Synthetic Fluid XTEND DUTY can be used for compressors operating at ambient temperatures between 0 °C (32 °F) and 46 °C (115 °F).

Roto Synthetic Fluid XTEND DUTY is the standard lubricant for oil injected screw compressors equipped with freeze protection or Energy Recovery.

See the table below for oil exchange intervals:

Ambient temperature	Element outlet temperature	Exchange interval	Maximum time interval
up to 35°C (95°F)	up to 100°C (212°F)	8000	2 years
from 35°C (95°F) up to 40°C (104°F) (see note)	from 100°C (212°F) up to 105°C (221°F)	6000	2 years
above 40°C (104°F)	above 105°C (221°F)	5000	2 years

Note: the presence of dust and/or high humidity may require a shorter exchange interval. Consult Atlas Copco.

Roto-Foodgrade Fluid

Special oil, delivered as an option.

Atlas Copco's Roto-Foodgrade Fluid is a unique high quality synthetic lubricant, specifically created for oil injected screw compressors that provide air for the food and beverage industry. This lubricant keeps the compressor in excellent condition. Roto-Foodgrade Fluid can be used for compressors operating at ambient temperatures between 0 °C (32 °F) and 40 °C (104 °F).

Roto-Foodgrade Fluid has all required certification for use in food & beverage industry: like NSF-H1, Kosher, Halal and Allergen Free approvals.

See the table below for oil exchange intervals:

Ambient temperature	Element outlet temperature	Exchange interval	Maximum time interval
up to 35°C (95°F) (see note)	up to 100°C (212°F)	4000	1 year
from 35°C (95°F) up to 40°C (104°F) (see note)	from 100°C (212°F) up to 105°C (221°F)	3000	1 year
from 40°C (104°F) up to 45°C (113°F) (see note)	from 105°C (221°F) up to 110°C (230°F)	2000	1 year
above 45°C (113°F)	above 110°C (230°F)	use not recommended	use not recommended

Note: the presence of dust and/or high humidity may require a shorter exchange interval. Consult Atlas Copco.

* Whichever comes first.

12.3 Storage after installation

Procedure

Run the compressor regularly, e.g. twice a week, until warm. Load and unload the compressor a few times.



NOTE

If the compressor is going to be stored without running from time to time, protective measures must be taken. Consult your supplier.

12.4 Service kits

Service kits

For overhauling and preventive maintenance, a wide range of service kits is available. They comprise all parts required for servicing the component and offer the benefits of genuine Atlas Copco parts while keeping the maintenance budget low.

A full range of extensively tested lubricants suitable for your specific needs is also available to keep the compressor in excellent condition.

Consult the Spare Parts List for part numbers.

13 Adjustments and servicing procedures

13.1 Drive motor

General

Keep the outside of the electric motor clean for efficient cooling. If necessary, remove dust with a brush and/or compressed air jet.

Bearing maintenance

The motor bearings do not need to be regreased during their normal service life.

13.2 Air filter

Location of air filter

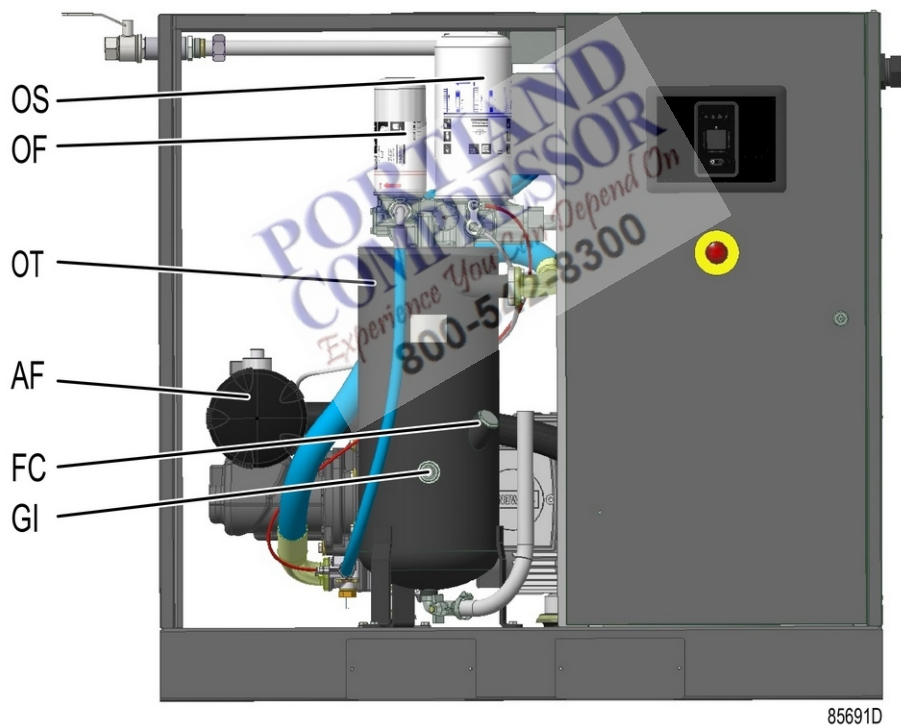

Figure 37: Location of air filter - GA 15, GA 18, GA 22, GA 26

Recommendations

1. Never remove the filtration element while the compressor is running.
2. For minimum downtime, replace the dirty element by a new one.
3. Discard the element when damaged.

Procedure

1. Stop the compressor and switch off the voltage.

2. Remove the side panel.
3. Remove the cover of the air filter (AF) by turning it anti-clockwise. Remove the filter element and if necessary, clean the cover.
4. Fit the new element and the cover.
5. Reset the air filter service warning.

13.3 Oil and oil filter change

WARNING

Always apply all relevant safety precautions.

Always drain the compressor oil at all drain points. Used oil left in the compressor can contaminate the oil system and can shorten the lifetime of the new oil.



Never mix lubricants of different brands or types as they may not be compatible and the oil mix will have inferior properties. A label, indicating the type of oil filled ex factory, is stuck on the air receiver/oil tank.

If the compressor is equipped with an Energy Recovery module, also drain the oil in the heat exchanger.

Procedure

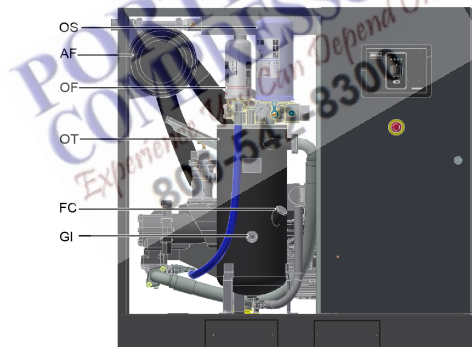

1. Run the compressor until warm. Stop the compressor. Close the air outlet valve and switch off the voltage. Depressurize the compressor by opening the manual drain valve(s). Wait a few minutes and depressurize the air receiver/oil tank (OT) by unscrewing the oil filler plug (FC) just one turn to permit any pressure to escape.
2. Open the filler plug (FC) and drain the oil by opening the valve at the bottom of the oil tank. Also remove the drain plug near the element outlet. Close the drain valve and fit the plugs after draining.
3. Collect the oil and deliver it to the local collection service. Refit and tighten the drain and vent plugs after draining. Tighten the top connection of the oil cooler.
4. Remove the oil filter (OF). Clean the seat on the manifold. Oil the gasket of the new filter and screw it into place. Tighten firmly by hand.
5. Remove the filler plug (FC).

Insert an elbow coupling in the filler plug opening for easy filling. Fill the air receiver/oil tank (OT) with oil until the level reaches the middle of sight-glass (GI).

Take care that no dirt drops into the system. Refit and tighten the filler plug (FC).

6. Run the compressor loaded for a few minutes. Stop the compressor and wait a few minutes to allow the oil to settle.
7. Depressurize the system by unscrewing the filler plug (FC) just one turn to permit any pressure in the system to escape. Remove the plug.

Add oil until the sight glass (GI) is full.

Take care that no dirt enters the system. Tighten the filler plug.

8. Reset the service warning after carrying out all service actions in the relevant Service Plan.

13.4 Oil separator change



WARNING

The operator must apply all relevant safety precautions.

1. Run the compressor until warm. Stop the compressor, close the air outlet valve and switch off the voltage. Wait a few minutes and depressurize by unscrewing the oil filler plug (FC) just one turn to permit any pressure in the system to escape.
2. Wait 5 minutes and remove the oil separator (OS). Clean the seat on the manifold. Oil the gasket of the new separator and screw it into place. Tighten firmly by hand.
3. Reset the service timer:

For compressors equipped with an Elektronikon™ Swipe controller, see section *Service menu*.

For compressors equipped with an Elektronikon™ Touch controller, see section *Service menu*.

13.5 Coolers

General

Keep the coolers clean to maintain their efficiency.



DANGER

Never use a high pressure water jet to clean the compressor.

Instructions for air-cooled compressors

- Stop the compressor, close the air outlet valve and switch off the voltage.
- Cover all parts under the coolers.
- Remove any dirt from the coolers with a fiber brush. Never use a wire brush or metal objects.
- Next, clean with an air jet in the reverse direction to the normal flow. Use low pressure air. If necessary, the pressure may be increased up to 6 bar(e) (87 psig).
- If it is necessary to wash the coolers with a cleaning agent, consult Atlas Copco.

13.6 Safety valves

Testing

Before removing the valve, depressurize the compressor. See also section *Problem solving*.

The safety valve (SV) can be tested on a separate air line. If the valve does not open at the set pressure stamped on the valve, it needs to be replaced.

An additional safety valve is fitted on tank mounted versions. The valve can be tested on a separate air line. If the valve does not open at the set pressure stamped on the valve, it needs to be replaced.



WARNING

No adjustments are allowed. Never run the compressor without safety valve.

13.7 Dryer maintenance instructions

Safety precautions

Refrigeration dryers of ID type contain refrigerant HFC.

When handling refrigerant, all applicable *Safety precautions* must be observed. Please be specifically aware of the following points:

- Contact of refrigerant with the skin will cause freezing. Special gloves must be worn. If contacted with the skin, the skin should be rinsed with water. On no account may clothing be removed.
- Fluid refrigerant will also cause freezing of the eyes; always wear safety glasses.
- Refrigerant is harmful. Do not inhale refrigerant vapors. Check that the working area is adequately ventilated.

Be aware that certain components, such as the refrigerant compressor and the discharge pipe, can become quite hot (up to 110 °C - 230 °F). Therefore, wait until the dryer has cooled down before removing the panels.

Before starting any maintenance or repair work, switch off the voltage and close the air inlet and outlet valves.

Local legislation

Local legislation may stipulate that:

- Work on the refrigerant circuit of the cooling dryer or on any equipment which influences its function must be undertaken by an authorized control body.
- The installation should be checked once a year by an authorized control body.

General

For all references see section *Introduction*.

The following remarks should be kept in mind:

- Keep the dryer clean.
- Brush or blow off the finned surface of condenser monthly.
- Inspect and clean the electronic condensate drain monthly.

14 Problem solving

WARNING



Before carrying out any maintenance, repair work or adjustment, press the stop button, wait until the compressor has stopped, press the emergency stop button and switch off the voltage. Close the air outlet valve, open the manual drain valve. Depressurise the compressor by opening the oil filler plug (FC) one turn.

For location of components, see sections *Introduction*, *Condensate system* and *Initial start-up*.

Open and lock the isolating switch.

WARNING



The air outlet valve can be locked during maintenance or repair as follows:

- Close the valve.
- Remove the screw fixing the handle with the wrench delivered with the compressor.
- Lift the handle and turn it until the slot of the handle fits over the blocking edge on the valve body.
- Fit the screw.

Always apply all relevant safety precautions.

Faults and remedies, compressor

Condition	Fault	Remedy
Compressor starts running, but does not load after a delay time	Solenoid valve out of order	Replace valve
	Inlet valve stuck in closed position	Have valve checked
	Leak in control air tubes	Replace leaking tubes
Compressor does not unload, safety valve blows	Minimum pressure valve leaking (when net is depressurized)	Have valve checked
	Solenoid valve out of order	Replace valve
Compressor does not unload, safety valve blows	Inlet valve does not close	Have valve checked
	Discharge tube clogged	Check and correct as necessary
Compressor air output or pressure below normal	Air consumption exceeds air delivery of compressor	Check equipment connected
	Choked air filter element	Replace filter element
	Solenoid valve malfunctioning	Replace valve
	Leak in control air tubes	Replace leaking tubes
	Inlet valve does not fully open	Have valve checked
	Air leakage	Have leaks repaired
	Safety valve leaking	Have valve replaced
	Compressor element out of order	Consult Atlas Copco
Excessive oil consumption; oil carry-over through discharge line	Incorrect oil causing foam	Change to correct oil

Condition	Fault	Remedy
	Oil level too high	Check for overfilling. Release pressure and drain oil to correct level.
	Oil separator defective	Replace oil separator element
	Malfunctioning of the scavenge line	Replace non-return valve in the scavenge line
Safety valve blows after loading	Inlet valve malfunctioning	Have valve checked
	Minimum pressure valve malfunctioning	Have valve checked
	Safety valve out of order	Have valve replaced
	Compressor element out of order	Consult Atlas Copco
	Oil separator element clogged	Replace oil separator element
Compressor element outlet temperature or delivery air temperature above normal	Oil level too low	Check and correct
	On air-cooled compressors, insufficient cooling air or cooling air temperature too high	Check for cooling air restriction or improve ventilation of the compressor room. Avoid recirculation of cooling air. If installed, check capacity of compressor room fan
	Oil cooler clogged	Clean cooler
	Bypass valve malfunctioning	Have valve tested
	Air cooler clogged	Clean cooler
	Compressor element out of order	Consult Atlas Copco Customer Center

Faults and remedies, dryer

For all references hereafter, consult section *Air dryer*.

Condition	Fault	Remedy
Pressure dew point too high	Air inlet temperature too high	Check and correct; if necessary, clean the aftercooler of the compressor
	Ambient temperature too high	Check and correct; if necessary, draw cooling air via a duct from a cooler place or relocate the compressor
	Shortage of refrigerant	Have circuit checked for leaks and recharged
	Refrigerant compressor does not run	See below
	Evaporator pressure too high	See below
	Condenser pressure too high	See below
Condenser pressure too high or too low	Fan control switch out of order	Replace
	Fan blades or fan motor out of order	Check fan/fan motor
	Ambient temperature too high	Check and correct; if necessary, draw cooling air via a duct from a cooler place or relocate the compressor
	Condenser externally clogged	Clean condenser
Compressor stops or does not start	Electric power supply to compressor is interrupted	Check and correct as necessary

Condition	Fault	Remedy
	Thermal protection of refrigerant compressor motor has tripped	Motor will restart when motor windings have cooled down
Electronic condensate drain remains inoperative	Electronic drain system clogged	Have system inspected Clean the filter of the automatic drain by opening the manual drain valve. Check functioning of the drain by pushing the test button.
Condensate trap continuously discharges air and water	Automatic drain out of order	Have system checked. If necessary, replace the automatic drain.
Evaporator pressure is too high or too low at unload	Hot gas bypass valve incorrectly set or out of order	Have hot gas bypass valve adjusted
	Condenser pressure too high or too low	See above
	Shortage of refrigerant	Have circuit checked for leaks and recharged if necessary

**PORTLAND
COMPRESSOR**
Experience You Can Depend On
800-542-8300

15 Technical data

15.1 Readings on display

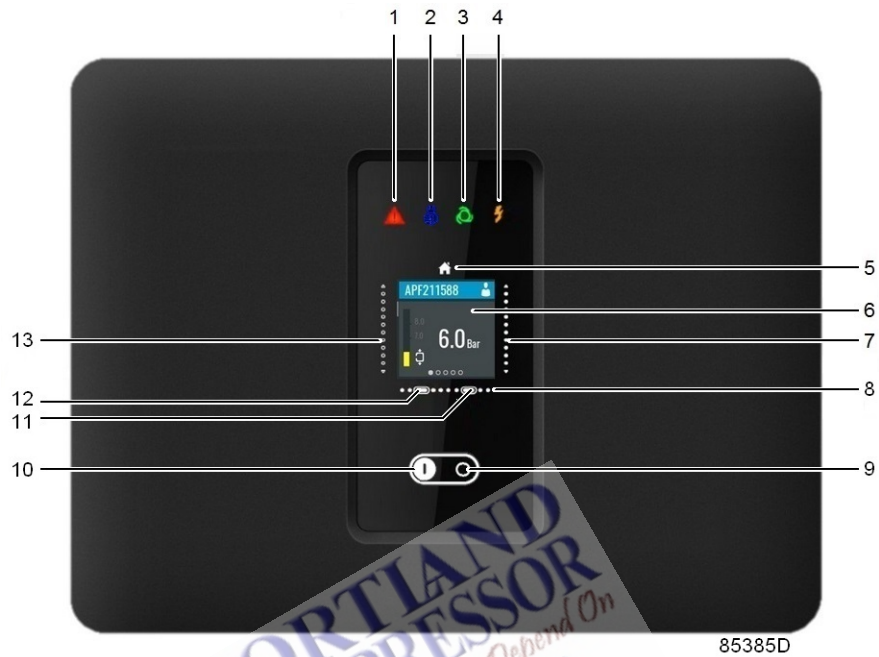

Figure 38: Control panel Elektronikon™ Swipe

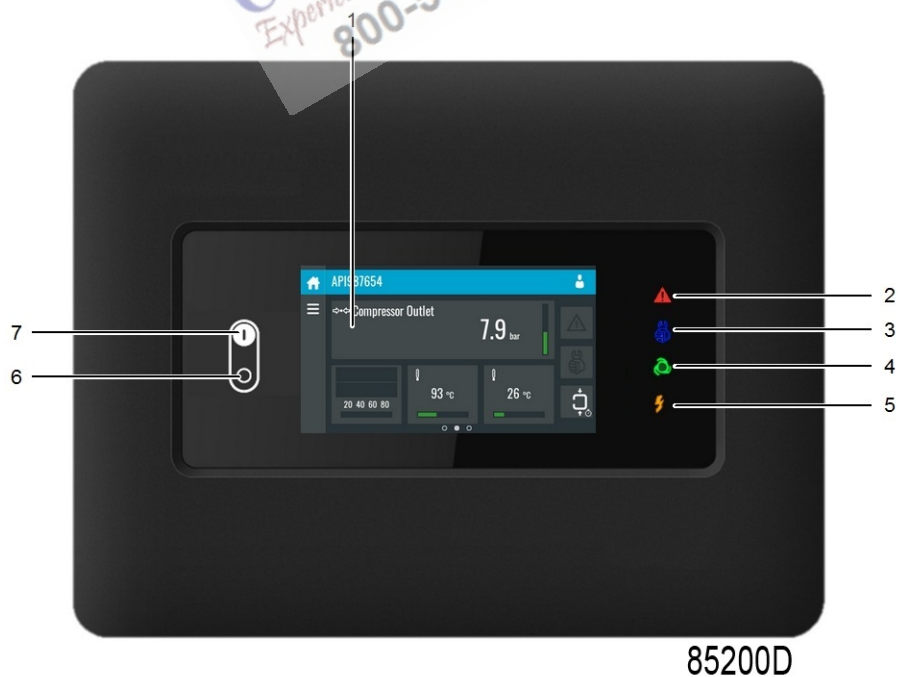

Figure 39: Control panel Elektronikon™ Touch

Important



NOTE

The readings mentioned below are valid under the reference conditions (see section *Reference conditions and limitations*).

Reference	Reading
Air outlet pressure	Fluctuates between programmed unloading and loading pressures.
Compressor element outlet temperature	55-65 °C (99-117 °F) above cooling air temperature.
Dew point temperature	For compressors with built-in dryer: see section <i>Compressor data</i> .

15.2 Electric cable size and main fuses

IMPORTANT



- The voltage on the compressor terminals must not deviate more than 10% of the nominal voltage.

It is however highly recommended to keep the voltage drop over the supply cables at nominal current below 5% of the nominal voltage (IEC 60204-1). If cables are grouped together with other power cables, it may be necessary to use cables of a larger size than those calculated for the standard operating conditions.

- Use the original cable entry. See section Dimension drawings.

To preserve the protection degree of the electric cubicle and to protect its components from dust from the environment, it is mandatory to use a proper cable gland when connecting the supply cable to the compressor.

- Local regulations remain applicable if they are stricter than the values proposed below.

IEC versions

For IEC designed control panels, the below suggested *cable sections* are calculated according to 60364-5-52 (Electrical installations of buildings - selection and erection equipment - current-carrying capacities in wiring systems).

Standard conditions refer to multi core copper cables with 70 °C PVC or 90 °C XLPE/EPR insulation in cable conduits or cable trunking systems (installation method B2) at 30 °C ambient temperature and operating at nominal voltage. The cables may not be grouped with other power circuits or cables.

Worst case conditions refer to:

- Ambient temperature > 30 °C (86 °F)
- Cables in closed raceway, conduit or trunking system (installation method B2) at 46 °C ambient temperature
- Cables not grouped with other cables

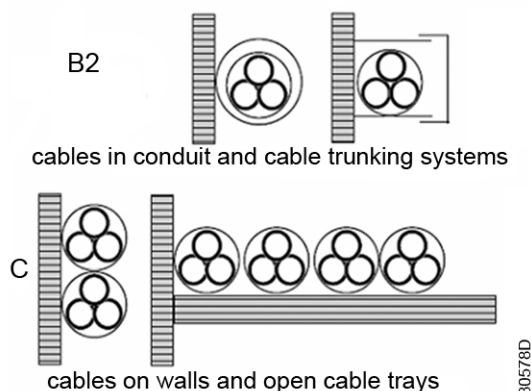

Figure 40:

Fuse calculations for IEC are done according to 60364-4-43 *electrical installations of buildings*, part 4: *protection for safety*- section 43: *protection against overcurrent*. Fuse sizes are calculated in order to protect the cable against short circuit. Fuse type aM is recommended but gG/gL is also allowed.

UL/cUL versions

For **UL** designed industrial control panels, calculations for **cable sections and fuses** are done according to UL508a (Industrial control panels).

For **cUL**, calculations for **cable sections and fuses** are done according to CSA22.2 (Canadian electrical code).

Standard conditions: maximum 3 copper conductors in raceway or cable with 85-90°C (185-194 °F) insulation at ambient temperature 30 °C (86 °F), operating at nominal voltage; cables not grouped with other cables.

Worst case conditions: ambient temperature > 30 °C (86 °F), max. 3 copper conductors in raceway or cable with 85-90 °C (185-194 °F) insulation at 46 °C (115 °F) ambient temperature and operating at nominal voltage. Cables not grouped with other cables.

Fuse size is the maximum fuse size in order to protect the motor against short circuit. For cUL fuse HRC form II, for UL fuse class RK5.

If the local conditions are more severe than the described standard conditions, the cables and fuses for worst case conditions should be used.

Recommended cable size

Type	V	Hz	Approval	I _{tot} P (1)	I _{tot} FF (1)	Recommended wire section (2)	Recommended wire section (3)	Main fuses P (A) (4)	Main fuses FF (A) (4)
GA 15	230	50	IEC	58.1	68.1	35 mm ² / 16 mm ²	35 mm ² / 25 mm ²	100	100
GA 15	230	60	IEC	59.3	69.3	35 mm ² / 16 mm ²	35 mm ² / 25 mm ²	100	100
GA 15	380	60	IEC	29.7	35.7	16 mm ² / 10 mm ²	16 mm ² / 10 mm ²	50	50
GA 15	400	50	IEC	33.3	39	16 mm ² / 6 mm ²	16 mm ² / 10 mm ²	50	50

Type	V	Hz	Approval	I _{totP} (1)	I _{totFF} (1)	Recommended wire section (2)	Recommended wire section (3)	Main fuses P (A) (4)	Main fuses FF (A) (4)
GA 15	460	60	IEC	29.6	34.6	10 mm ² / 6 mm ²	16 mm ² / 6 mm ²	50	50
GA 15	200	60	cULus / cCSAus	66.7	78.2	AWG4	AWG3	80	100
GA 15	230	60	cULus / cCSAus	59.3	69.3	AWG4	AWG3	80	100
GA 15	460	60	cULus / cCSAus	29.7	34.7	AWG8	AWG8	50	50
GA 15	575	60	cULus / cCSAus	26.3	30.3	AWG8	AWG8	40	40
GA 18	230	50	IEC	70.5	80.5	50 mm ² / 25 mm ²	50 mm ² / 25 mm ²	125	125
GA 18	230	60	IEC	71.3	81.3	50 mm ² / 25 mm ²	50 mm ² / 25 mm ²	125	125
GA 18	380	60	IEC	35.7	41.7	16 mm ² / 10 mm ²	25 mm ² / 10 mm ²	63	63
GA 18	400	50	IEC	40.7	46.4	16 mm ² / 10 mm ²	25 mm ² / 10 mm ²	63	63
GA 18	460	60	IEC	35.6	40.6	16 mm ² / 10 mm ²	16 mm ² / 10 mm ²	63	63
GA 18	200	60	cULus / cCSAus	79.9	91.4	AWG3	AWG2	100	125
GA 18	230	60	cULus / cCSAus	71.3	81.3	AWG3	AWG2	100	125
GA 18	460	60	cULus / cCSAus	35.7	40.7	AWG8	AWG6	50	60
GA 18	575	60	cULus / cCSAus	31.1	35.1	AWG8	AWG8	50	50
GA 22	230	50	IEC	82.5	92.5	70 mm ² / 35 mm ²	70 mm ² / 35 mm ²	160	160
GA 22	230	60	IEC	83.8	93.8	70 mm ² / 35 mm ²	70 mm ² / 35 mm ²	160	160
GA 22	380	60	IEC	42	48	25 mm ² / 16 mm ²	25 mm ² / 16 mm ²	80	80
GA 22	400	50	IEC	47.4	53.1	25 mm ² / 10 mm ²	25 mm ² / 16 mm ²	80	80
GA 22	460	60	IEC	41.9	46.9	16 mm ² / 10 mm ²	25 mm ² / 10 mm ²	80	80
GA 22	200	60	cULus / cCSAus	94.8	106.3	AWG1	AWG1/0	125	150
GA 22	230	60	cULus / cCSAus	83.7	93.7	AWG1	AWG1/0	125	150
GA 22	460	60	cULus / cCSAus	41.9	46.9	AWG6	AWG4	60	70
GA 22	575	60	cULus / cCSAus	35.9	39.9	AWG8	AWG6	50	60
GA 26	230	50	IEC	99.3	109.3	70 mm ² / 35 mm ²	95 mm ² / 50 mm ²	160	160
GA 26	230	60	IEC	99.9	109.9	70 mm ² / 35 mm ²	95 mm ² / 50 mm ²	160	160
GA 26	380	60	IEC	50.2	56.2	35 mm ² / 16 mm ²	35 mm ² / 25 mm ²	125	125

Type	V	Hz	Approval	I _{totP} (1)	I _{totFF} (1)	Recommended wire section (2)	Recommended wire section (3)	Main fuses P (A) (4)	Main fuses FF (A) (4)
GA 26	400	50	IEC	57	62.7	25 mm ² / 16 mm ²	35 mm ² / 16 mm ²	80	80
GA 26	460	60	IEC	50.1	55.1	25 mm ² / 16 mm ²	25 mm ² / 16 mm ²	80	80
GA 26	200	60	cULus / cCSAus	111.8	123.3	AWG1/0	AWG2/0	150	175
GA 26	230	60	cULus / cCSAus	99.6	109.6	AWG1/0	AWG2/0	150	175
GA 26	460	60	cULus / cCSAus	50	55	AWG4	AWG4	80	80
GA 26	575	60	cULus / cCSAus	41.9	45.9	AWG6	AWG6	60	60
GA 30	230	50	IEC	124	131.5	70 mm ² / 35mm ²	95 mm ² / 50mm ²	160	160
GA 30	230	60	IEC	117	124.6	70 mm ² / 35mm ²	95 mm ² / 50mm ²	160	160
GA 30	380	60	IEC	70.7	75.3	50 mm ² / 25mm ²	50 mm ² / 25mm ²	80	80
GA 30	400	50	IEC	70.4	74.9	50 mm ² / 25mm ²	50 mm ² / 25mm ²	80	80
GA 30	460	60	IEC	59	62.8	50 mm ² / 25mm ²	50 mm ² / 25mm ²	80	80
GA 30	230	60	cULus / cCSAus	117	124.6	AWG1/0	AWG2/0	150	175
GA 30	460	60	cULus / cCSAus	59	62.8	AWG4	AWG4	80	80
GA 30	575	60	cULus / cCSAus	46	50.3	AWG4	AWG4	70	80

Remarks :

- (1): current in the supply lines at maximum load and nominal voltage
- (2): suggested wire section under worst case conditions (Pack)
- (3): suggested wire section under worst case conditions (Full-Feature)
- (4): Maximum fuse value

Fuse specifications IEC: aM

Fuse specifications UL/cUL: HRC Form II - UL: Class RK5

15.3 Motor overload relay settings

Type	V	Hz	Approval	Setting F21 (A)	Setting Q15 (A)
GA 15	230	50	IEC	36	0.7
GA 15	230	60	IEC	36.6	0.7
GA 15	380	60	IEC	25.9	0.4
GA 15	400	50	IEC	20.6	0.4
GA 15	460	60	IEC	18.3	0.4
GA 15	200	60	cULus / cCSAus	41.2	0.7
GA 15	230	60	cULus / cCSAus	36.6	0.7
GA 15	460	60	cULus / cCSAus	18.3	0.5
GA 15	575	60	cULus / cCSAus	14.5	0.5

Type	V	Hz	Approval	Setting F21 (A)	Setting Q15 (A)
GA 18	230	50	IEC	43.5	1.1
GA 18	230	60	IEC	44.3	0.7
GA 18	380	60	IEC	25.9	0.4
GA 18	400	50	IEC	25.2	0.6
GA 18	460	60	IEC	22.1	0.4
GA 18	200	60	cULus / cCSAus	49.6	0.7
GA 18	230	60	cULus / cCSAus	44.3	0.7
GA 18	460	60	cULus / cCSAus	22.1	0.5
GA 18	575	60	cULus / cCSAus	17.5	0.5
GA 22	230	50	IEC	50.4	2.5
GA 22	230	60	IEC	51.9	1.2
GA 22	380	60	IEC	30.5	0.7
GA 22	400	50	IEC	29	1.3
GA 22	460	60	IEC	25.9	0.7
GA 22	200	60	cULus / cCSAus	58.8	1.3
GA 22	230	60	cULus / cCSAus	51.9	1.2
GA 22	460	60	cULus / cCSAus	25.9	0.7
GA 22	575	60	cULus / cCSAus	20.6	0.7
GA 26	230	50	IEC	61	2.5
GA 26	230	60	IEC	61	2.9
GA 26	380	60	IEC	36.6	1.7
GA 26	400	50	IEC	35.1	1.3
GA 26	460	60	IEC	30.5	1.7
GA 26	200	60	cULus / cCSAus	68.7	2.9
GA 26	230	60	cULus / cCSAus	61	2.9
GA 26	460	60	cULus / cCSAus	30.5	1.7
GA 26	575	60	cULus / cCSAus	24.4	1.7
GA 30	230	50	IEC	76	2.5
GA 30	230	60	IEC	73	2.9
GA 30	380	60	IEC	43	1.7
GA 30	400	50	IEC	43	1.3
GA 30	460	60	IEC	36	1.7
GA 30	230	60	cULus / cCSAus	72	2.9
GA 30	460	60	cULus / cCSAus	36	1.7
GA 30	575	60	cULus / cCSAus	44	1.7

15.4 Dryer switches

General

The regulating and safety devices are factory-adjusted to give optimum performance of the dryer.

Do not alter the setting of any of the devices.

15.5 Reference conditions and limitations

Reference conditions

Characteristic	Unit	Data
Air inlet pressure (absolute)	bar	1

Characteristic	Unit	Data
Air inlet pressure (absolute)	psi	14.5
Air inlet temperature	°C	20
Air inlet temperature	°F	68
Relative humidity	%	0
Working pressure		See section <i>Compressor data</i>

Limitations

Characteristic	Unit	Data
Maximum working pressure		See section <i>Compressor data</i>
Minimum working pressure	bar	6
Minimum working pressure	psi	87
Maximum ambient temperature	°C	46
Maximum ambient temperature	°F	115
Minimum ambient temperature	°C	0
Minimum ambient temperature	°F	32

15.6 Compressor data

Reference conditions



NOTE

All data specified below apply under reference conditions, see section *Reference conditions and limitations*.

GA 15

		7.5 bar	8.5 bar	10.0 bar	13.0 bar	100 psi	125 psi	150 psi	175 psi
Frequency	Hz	50	50	50	50	60	60	60	60
Maximum (unloading) pressure, Pack	bar(e)	7.5	8.5	10	13	7.4	9.1	10.8	12.5
Maximum (unloading) pressure, Pack	psig	109	123	145	189	107	132	157	181
Maximum (unloading) pressure, Full-Feature units	bar(e)	7.3	8.3	9.8	12.8	7.15	8.85	10.55	12.25
Maximum (unloading) pressure, Full-Feature units	psig	106	120	142	186	104	128	153	178
Nominal working pressure	bar(e)	7	8	9.5	12.5	6.9	8.6	10.3	12
Nominal working pressure	psig	102	116	138	181	100	125	150	175
Pressure drop over dryer, Full-Feature units	bar(e)	0.2	0.2	0.2	0.2	0.2	0.2	0.2	0.2
Pressure drop over dryer, Full-Feature units	psig	3	3	3	3	3	3	3	3
Motor shaft speed	r/min	2960	2960	2960	2960	3565	3565	3565	3565

		7.5 bar	8.5 bar	10.0 bar	13.0 bar	100 psi	125 psi	150 psi	175 psi
Set point, thermostatic valve	°C	60	60	60	60	60	60	60	60
Set point, thermostatic valve	°F	140	140	140	140	140	140	140	140
Temperature of air leaving outlet valve (approx.), Pack	°C	30	30	30	30	30	30	30	30
Temperature of air leaving outlet valve (approx.), Pack	°F	86	86	86	86	86	86	86	86
Temperature of air leaving outlet valve (approx.), Full-Feature units	°C	20	20	20	20	20	20	20	20
Temperature of air leaving outlet valve (approx.), Full-Feature units	°F	68	68	68	68	68	68	68	68
Pressure dew point, Full-Feature units	°C	3	3	3	3	3	3	3	3
Pressure dew point, Full-Feature units	°F	37.4	37.4	37.4	37.4	37.4	37.4	37.4	37.4
Nominal motor power	kW	15	15	15	15	15	15	15	15
Nominal motor power	hp	20.1	20.1	20.1	20.1	20.1	20.1	20.1	20.1
Refrigerant type, Full-Feature units (except cCSAus)		R513A	R513A	R513A	R513A	R513A	R513A	R513A	R513A
Refrigerant type, Full-Feature units (cCSAus)						R513A	R513A	R513A	R513A
Refrigerant quantity, Full-Feature units (except cCSAus)	kg	0.3	0.3	0.3	0.3	0.3	0.3	0.3	0.3
Refrigerant quantity, Full-Feature units (except cCSAus)	lb	0.66	0.66	0.66	0.66	0.66	0.66	0.66	0.66
Refrigerant quantity, Full-Feature units (cCSAus)	kg					0.3	0.3	0.3	0.3
Refrigerant quantity, Full-Feature units (cCSAus)	lb					0.66	0.66	0.66	0.66
Oil capacity	l	12.2	12.2	12.2	12.2	12.2	12.2	12.2	12.2
Oil capacity	US gal	3.2	3.2	3.2	3.2	3.2	3.2	3.2	3.2
Sound pressure level, Pack and Full-Feature (according to ISO 2151 (2004))	dB(A)	65	65	65	65	65	65	65	65

GA 18

		7.5 bar	8.5 bar	10.0 bar	13.0 bar	100 psi	125 psi	150 psi	175 psi
Frequency	Hz	50	50	50	50	60	60	60	60

		7.5 bar	8.5 bar	10.0 bar	13.0 bar	100 psi	125 psi	150 psi	175 psi
Maximum (unloading) pressure, Pack	bar(e)	7.5	8.5	10	13	7.4	9.1	10.8	12.5
Maximum (unloading) pressure, Pack	psig	109	123	145	189	107	132	157	181
Maximum (unloading) pressure, Full-Feature	bar(e)	7.3	8.3	9.8	12.8	7.15	8.85	10.55	12.25
Maximum (unloading) pressure, Full-Feature	psig	106	120	142	186	104	128	153	178
Nominal working pressure	bar(e)	7	8	9.5	12.5	6.9	8.6	10.3	12
Nominal working pressure	psig	102	116	138	181	100	125	150	175
Pressure drop over dryer, Full-Feature units	bar(e)	0.2	0.2	0.2	0.2	0.2	0.2	0.2	0.2
Pressure drop over dryer, Full-Feature units	psig	3	3	3	3	3	3	3	3
Motor shaft speed	r/min	2955	2955	2955	2955	3560	3560	3560	3560
Set point, thermostatic valve	°C	60	60	60	60	60	60	60	60
Set point, thermostatic valve	°F	140	140	140	140	140	140	140	140
Temperature of air leaving outlet valve (approx.), Pack	°C	30	30	30	30	30	30	30	30
Temperature of air leaving outlet valve (approx.), Pack	°F	86	86	86	86	86	86	86	86
Temperature of air leaving outlet valve (approx.), Full-Feature units	°C	20	20	20	20	20	20	20	20
Temperature of air leaving outlet valve (approx.), Full-Feature units	°F	68	68	68	68	68	68	68	68
Pressure dew point, Full-Feature units	°C	3	3	3	3	3	3	3	3
Pressure dew point, Full-Feature units	°F	37.4	37.4	37.4	37.4	37.4	37.4	37.4	37.4
Nominal motor power	kW	18.5	18.5	18.5	18.5	18.5	18.5	18.5	18.5
Nominal motor power	hp	24.8	24.8	24.8	24.8	24.8	24.8	24.8	24.8
Refrigerant type, Full-Feature units (except cCSAus)		R410A	R410A	R410A	R410A	R410A	R410A	R410A	R410A
Refrigerant type, Full-Feature units (cCSAus)						R513A	R513A	R513A	R513A
Refrigerant quantity, Full-Feature units (except cCSAus)	kg	0.7	0.7	0.7	0.7	0.6	0.6	0.6	0.6
Refrigerant quantity, Full-Feature units (except cCSAus)	lb	1.54	1.54	1.54	1.54	1.32	1.32	1.32	1.32

		7.5 bar	8.5 bar	10.0 bar	13.0 bar	100 psi	125 psi	150 psi	175 psi
Refrigerant quantity, Full-Feature units (cCSAus)	kg					0.5	0.5	0.5	0.5
Refrigerant quantity, Full-Feature units (cCSAus)	lb					1.10	1.10	1.10	1.10
Oil capacity	l	12.2	12.2	12.2	12.2	12.2	12.2	12.2	12.2
Oil capacity	US gal	3.2	3.2	3.2	3.2	3.2	3.2	3.2	3.2
Sound pressure level, Pack and Full-Feature (according to ISO 2151 (2004))	dB(A)	67	67	67	67	67	67	67	67

GA 22

		7.5 bar	8.5 bar	10.0 bar	13.0 bar	100 psi	125 psi	150 psi	175 psi
Frequency	Hz	50	50	50	50	60	60	60	60
Maximum (unloading) pressure, Pack	bar(e)	7.5	8.5	10	13	7.4	9.1	10.8	12.5
Maximum (unloading) pressure, Pack	psig	109	123	145	189	107	132	157	181
Maximum (unloading) pressure, Full-Feature	bar(e)	7.3	8.3	9.8	12.8	7.15	8.85	10.55	12.25
Maximum (unloading) pressure, Full-Feature	psig	106	120	142	186	104	128	153	178
Nominal working pressure	bar(e)	7	8	9.5	12.5	6.9	8.6	10.3	12
Nominal working pressure	psig	102	116	138	181	100	125	150	175
Pressure drop over dryer, Full-Feature units	bar(e)	0.2	0.2	0.2	0.2	0.2	0.2	0.2	0.2
Pressure drop over dryer, Full-Feature units	psig	3	3	3	3	3	3	3	3
Motor shaft speed	r/min	2950	2950	2950	2950	3565	3565	3565	3565
Set point, thermostatic valve	°C	60	60	60	60	60	60	60	60
Set point, thermostatic valve	°F	140	140	140	140	140	140	140	140
Temperature of air leaving outlet valve (approx.), Pack	°C	30	30	30	30	30	30	30	30
Temperature of air leaving outlet valve (approx.), Pack	°F	86	86	86	86	86	86	86	86
Temperature of air leaving outlet valve (approx.), Full-Feature units	°C	20	20	20	20	20	20	20	20
Temperature of air leaving outlet valve (approx.), Full-Feature units	°F	68	68	68	68	68	68	68	68

		7.5 bar	8.5 bar	10.0 bar	13.0 bar	100 psi	125 psi	150 psi	175 psi
Pressure dew point, Full-Feature units	°C	3	3	3	3	3	3	3	3
Pressure dew point, Full-Feature units	°F	37.4	37.4	37.4	37.4	37.4	37.4	37.4	37.4
Nominal motor power	kW	22	22	22	22	22	22	22	22
Nominal motor power	hp	29.5	29.5	29.5	29.5	29.5	29.5	29.5	29.5
Refrigerant type, Full-Feature units (except cCSAus)		R410A	R410A	R410A	R410A	R410A	R410A	R410A	R410A
Refrigerant type, Full-Feature units (cCSAus)						R513A	R513A	R513A	R513A
Refrigerant quantity, Full-Feature units (except cCSAus)	kg	0.7	0.7	0.7	0.7	0.6	0.6	0.6	0.6
Refrigerant quantity, Full-Feature units (except cCSAus)	lb	1.54	1.54	1.54	1.54	1.32	1.32	1.32	1.32
Refrigerant quantity, Full-Feature units (cCSAus)	kg					0.5	0.5	0.5	0.5
Refrigerant quantity, Full-Feature units (cCSAus)	lb					1.10	1.10	1.10	1.10
Oil capacity	l	12.2	12.2	12.2	12.2	12.2	12.2	12.2	12.2
Oil capacity	US gal	3.2	3.2	3.2	3.2	3.2	3.2	3.2	3.2
Sound pressure level, Pack and Full-Feature (according to ISO 2151 (2004))	dB(A)	68	68	68	68	68	68	68	68

GA 26

		7.5 bar	8.5 bar	10.0 bar	13.0 bar	100 psi	125 psi	150 psi	175 psi
Frequency	Hz	50	50	50	50	60	60	60	60
Maximum (unloading) pressure, Pack	bar(e)	7.5	8.5	10	13	7.4	9.1	10.8	12.5
Maximum (unloading) pressure, Pack	psig	109	123	145	189	107	132	157	181
Maximum (unloading) pressure, Full-Feature	bar(e)	7.3	8.3	9.8	12.8	7.15	8.85	10.55	12.25
Maximum (unloading) pressure, Full-Feature	psig	106	120	142	186	104	128	153	178
Nominal working pressure	bar(e)	7	8	9.5	12.5	6.9	8.6	10.3	12
Nominal working pressure	psig	102	116	138	181	100	125	150	175
Pressure drop over dryer, Full-Feature units	bar(e)	0.2	0.2	0.2	0.2	0.2	0.2	0.2	0.2
Pressure drop over dryer, Full-Feature units	psig	3	3	3	3	3	3	3	3
Motor shaft speed	r/min	2960	2960	2960	2960	3565	3565	3565	3565
Set point, thermostatic valve	°C	60	60	60	60	60	60	60	60

		7.5 bar	8.5 bar	10.0 bar	13.0 bar	100 psi	125 psi	150 psi	175 psi
Set point, thermostatic valve	°F	140	140	140	140	140	140	140	140
Temperature of air leaving outlet valve (approx.), Pack	°C	30	30	30	30	30	30	30	30
Temperature of air leaving outlet valve (approx.), Pack	°F	86	86	86	86	86	86	86	86
Temperature of air leaving outlet valve (approx.), Full-Feature units	°C	20	20	20	20	20	20	20	20
Temperature of air leaving outlet valve (approx.), Full-Feature units	°F	68	68	68	68	68	68	68	68
Pressure dew point, Full-Feature units	°C	3	3	3	3	3	3	3	3
Pressure dew point, Full-Feature units	°F	37.4	37.4	37.4	37.4	37.4	37.4	37.4	37.4
Nominal motor power	kW	26	26	26	26	26	26	26	26
Nominal motor power	hp	34.9	34.9	34.9	34.9	34.9	34.9	34.9	34.9
Refrigerant type, Full-Feature units (except cCSAus)		R410A	R410A	R410A	R410A	R410A	R410A	R410A	R410A
Refrigerant type, Full-Feature units (cCSAus)						R513A	R513A	R513A	R513A
Refrigerant quantity, Full-Feature units (except cCSAus)	kg	0.7	0.7	0.7	0.7	0.65	0.65	0.65	0.65
Refrigerant quantity, Full-Feature units (except cCSAus)	lb	1.54	1.54	1.54	1.54	1.43	1.43	1.43	1.43
Refrigerant quantity, Full-Feature units (cCSAus)	kg					0.7	0.7	0.7	0.7
Refrigerant quantity, Full-Feature units (CSAus)	lb					1.54	1.54	1.54	1.54
Oil capacity	l	12.2	12.2	12.2	12.2	12.2	12.2	12.2	12.2
Oil capacity	US gal	3.2	3.2	3.2	3.2	3.2	3.2	3.2	3.2
Sound pressure level, Pack and Full-Feature (according to ISO 2151 (2004))	dB(A)	69	69	69	69	69	69	69	69

GA 30

		7.5 bar	8.5 bar	10.0 bar	13.0 bar	100 psi	125 psi	150 psi	175 psi
Frequency	Hz	50	50	50	50	60	60	60	60
Maximum (unloading) pressure, Pack	bar(e)	7.5	8.5	10	13	7.4	9.1	10.8	12.5

		7.5 bar	8.5 bar	10.0 bar	13.0 bar	100 psi	125 psi	150 psi	175 psi
Maximum (unloading) pressure, Pack	psig	109	123	145	189	107	132	157	181
Maximum (unloading) pressure, Full-Feature	bar(e)	7.3	8.3	9.8	12.8	7.15	8.85	10.55	12.25
Maximum (unloading) pressure, Full-Feature	psig	106	120	142	186	104	128	153	178
Nominal working pressure	bar(e)	7	8	9.5	12.5	6.9	8.6	10.3	12
Nominal working pressure	psig	102	116	138	181	100	125	150	175
Pressure drop over dryer, Full-Feature units	bar(e)	0.2	0.2	0.2	0.2	0.2	0.2	0.2	0.2
Pressure drop over dryer, Full-Feature units	psig	3	3	3	3	3	3	3	3
Motor shaft speed	r/min	2940	2940	2940	2940	3540	3540	3540	3540
Set point, thermostatic valve	°C	60	60	60	60	60	60	60	60
Set point, thermostatic valve	°F	140	140	140	140	140	140	140	140
Temperature of air leaving outlet valve (approx.), Pack	°C	30	30	30	30	30	30	30	30
Temperature of air leaving outlet valve (approx.), Pack	°F	86	86	86	86	86	86	86	86
Temperature of air leaving outlet valve (approx.), Full-Feature units	°C	20	20	20	20	20	20	20	20
Temperature of air leaving outlet valve (approx.), Full-Feature units	°F	68	68	68	68	68	68	68	68
Pressure dew point, Full-Feature units	°C	3	3	3	3	3	3	3	3
Pressure dew point, Full-Feature units	°F	37.4	37.4	37.4	37.4	37.4	37.4	37.4	37.4
Nominal motor power	kW	30	30	30	30	30	30	30	30
Nominal motor power	hp	40.8	40.8	40.8	40.8	40.8	40.8	40.8	40.8
Refrigerant type, Full-Feature units (except cCSAus)		R410A	R410A	R410A	R410A	R410A	R410A	R410A	R410A
Refrigerant type, Full-Feature units (cCSAus)						R513A	R513A	R513A	R513A
Refrigerant quantity, Full-Feature units (except cCSAus)	kg	0.92	0.92	0.92	0.92	0.9	0.9	0.9	0.9
Refrigerant quantity, Full-Feature units (except cCSAus)	lb	2.03	2.03	2.03	2.03	1.98	1.98	1.98	1.98
Refrigerant quantity, Full-Feature units (cCSAus)	kg					0.6	0.6	0.6	0.6

		7.5 bar	8.5 bar	10.0 bar	13.0 bar	100 psi	125 psi	150 psi	175 psi
Refrigerant quantity, Full-Feature units (cCSAus)	lb					1.32	1.32	1.32	1.32
Oil capacity	l	12.2	12.2	12.2	12.2	12.2	12.2	12.2	12.2
Oil capacity	US gal	3.2	3.2	3.2	3.2	3.2	3.2	3.2	3.2
Sound pressure level, Pack and Full-Feature (according to ISO 2151 (2004))	dB(A)	73	73	73	73	73	73	73	73

15.7 Technical data of controller

General

Characteristic	Data
Supply voltage	24 V AC /16 VA 50/60Hz (+40%/-30%) 24 V DC/0.7 A
Type of protection	IP54 (front) IP21 (back)
<ul style="list-style-type: none"> Operating temperature range Storage temperature range 	<ul style="list-style-type: none"> -10°C.....+60°C (14 °F 140 °F) -30°C.....+70°C (-22 °F 158 °F)
Permissible humidity	Relative humidity 90% No condensation
Mounting	Cabinet door

Digital outputs

Characteristic	Data
Number of outputs	9 (Elektronikon™ Touch controller) 6 (Elektronikon™ Swipe controller)
Type	Relay (voltage free contacts)
Rated voltage AC	250 V AC / 10 A max.
Rated voltage DC	30 V DC / 10 A max.

Digital inputs

Characteristic	Data
Number of inputs	10 (Elektronikon™ Touch controller) 4 (Elektronikon™ Swipe controller)
Supply by controller	24 V DC
Supply protection	Short circuit protected to ground
Input protection	Not isolated

Analog inputs

Characteristic	Data
Number of pressure inputs	2 (Elektronikon™ Touch controller) 1 (Elektronikon™ Swipe controller)
Number of temperature inputs	5 (Elektronikon™ Touch controller) 3 (Elektronikon™ Swipe controller)

**PORTLAND
COMPRESSOR**
Experience You Can Depend On
800-542-8300

16 Instructions for use

Oil separator vessel

This vessel can contain pressurized air. This can be potentially dangerous if the equipment is misused.
This vessel must only be used as a compressed air/oil separator tank and must be operated within the limits specified on the data plate.
No alterations must be made to this vessel by welding, drilling or other mechanical methods without the written permission of the manufacturer.
The pressure and temperature of this vessel must be clearly indicated.
The safety valve must correspond with pressure surges of 1.1 times the maximum allowable operating pressure. It should guarantee that the pressure will not permanently exceed the maximum allowable operating pressure of the vessel.
Use only the oil as specified by the manufacturer.
In case of misuse of the units (very low oil temperature or a long shut down interval), a certain amount of condensate can gather in the oil separator vessel which must be properly drained. To do so, disconnect the unit from the power line, wait until it is cooled down and depressurized and drain the water via the oil drain valve, positioned at the bottom of the oil separator vessel. Local legislation may require a periodic inspection.

Air receiver (tank-mounted units)

Depending on the conditions of use, condensate may accumulate inside the air receiver. Drain the condensate every day in order to reduce the risk of corrosion. This may be done manually by opening the drain valve, or by means of the automatic drain, if fitted to the tank. Nevertheless, a weekly check is needed to ensure the automatic valve is functioning correctly. This has to be done by opening the manual drain valve and checking for condensate. Verify that no rust obstructions affect the drain system.
Yearly service inspection of the air receiver is needed, as internal corrosion can reduce the wall thickness with the consequent risk of bursting. The use of the air receiver is forbidden once the wall thickness reaches the minimum value as indicated in the service manual of the air receiver (part of the documentation delivered with the unit) or in section <i>Pressure equipment directives</i> . Local regulations remain applicable if they are more strict.
Lifetime of the air receiver mainly depends on the working environment. Installing the compressor in a dirty and corrosive environment is not allowed, as this can reduce the vessel lifetime dramatically.
Do not anchor the vessel or attached components directly to the ground or fixed structures. Fit the pressure vessel with vibration dampers to avoid possible fatigue failure caused by vibration of the vessel during use.
Use the vessel within the pressure and temperature limits stated on the nameplate and the testing report.
No alterations must be made to this vessel by welding, drilling or other mechanical methods.

17 Guidelines for inspection

Guidelines

On the Declaration of Conformity / Declaration by the Manufacturer, the harmonized and/or other standards that have been used for the design are shown and/or referred to.

The Declaration of Conformity / Declaration by the Manufacturer is part of the documentation that is supplied with this compressor.

Local legal requirements and/or use outside the limits and/or conditions as specified by the manufacturer may require other inspection periods as mentioned below.

**PORTLAND
COMPRESSOR**
Experience You Can Depend On
800-542-8300

18 Pressure equipment directives

Components subject to 2014/68/EU Pressure Equipment Directive

Compressor type	Part number	Description	PED class
GA 15 up to GA 30	2202889107 (CE) 0830101020 (ASME)	Safety valve	IV

Component	Description	Approval	Volume	Design pressure	Design temperature	PED class
1625 4815 01	Oil separator vessel		29 l	15 bar	-10 / 120 °C	SPV
2204 1005 01	Air receiver	CE	500 l	16 bar	-10 / 120 °C	SPV
2204 1005 03	Air receiver	ASME/CRN	500 l	200 psi	-10 / 120 °C	
2204 1005 02	Air receiver	DIR	500 l	1400 kPa	-10 / 120 °C	

Component	Description	Minimum wall thickness	Inspection frequency (1)
1625 4815 01	Oil separator vessel	See the declaration of the manufacturer of the vessel	10 years
2204 1005 01 2204 1005 02 2204 1005 03	Air receiver Air receiver Air receiver	See the declaration of the manufacturer of the vessel See the declaration of the manufacturer of the vessel See the declaration of the manufacturer of the vessel	1 year

(1) The minimum wall thickness must be respected at all times. Inspection techniques such as ultrasonic or X-ray are equivalent to hydrostatic testing for this equipment.

The compressors conform to PED smaller than category II.

19 Declaration of conformity

Insert logo here

EU DECLARATION OF CONFORMITY

2 We, (1) declare under our sole responsibility, that the product
 3 Machine name :
 4 Machine type :
 5 Serial number :

6 Which falls under the provisions of article 12.2 of the EC Directive 2006/42/EC on the approximation of the laws of the Member States relating to machinery, is in conformity with the relevant Essential Health and Safety Requirements of this directive.

The machinery complies also with the requirements of the following directives and their amendments as indicated.

	Directive on the approximation of laws of the Member States relating to	Harmonized and/or Technical Standards used	Att'mnt
a	(2)	(3)	
b			X
c			
d			X
e			
f			
g			X

8a The harmonized and the technical standards used are identified in the attachments hereafter

8b <1> is authorized to compile the technical file.

9 **Conformity of the specification to the directives** **Conformity of the product to the specification and by implication to the directives**

11 Issued by Engineering Manufacturing
 12 Name
 13 Signature
 14 Date
 15 Place

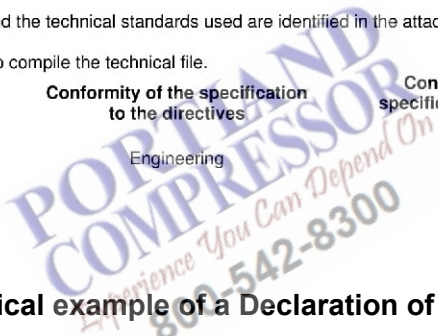

84390D

Figure 41: Typical example of a Declaration of Conformity document

- (1) Contact address:
Atlas Copco Airpower n.v.
P.O. Box 100
B-2610 Wilrijk (Antwerp)
Belgium
- (2) Applicable directives
- (3) Standards used

On the Declaration of Conformity / Declaration by the Manufacturer, the harmonized and/or other standards that have been used for the design are shown and/or referred to.

The Declaration of Conformity / Declaration by the Manufacturer is part of the documentation that is supplied with this device.

**PORTLAND
COMPRESSOR**
Experience You Can Depend On
800-542-8300

