

| REVISIONS | | | | | |
|-----------|----------|-----------------|-----------|--------|-----------|
| ZONE/REV | ECN | DESCRIPTION | DATE | DWN | APV |
| A | 09R00359 | INITIAL RELEASE | 2009AUG03 | G.LEVI | J.BALLARD |

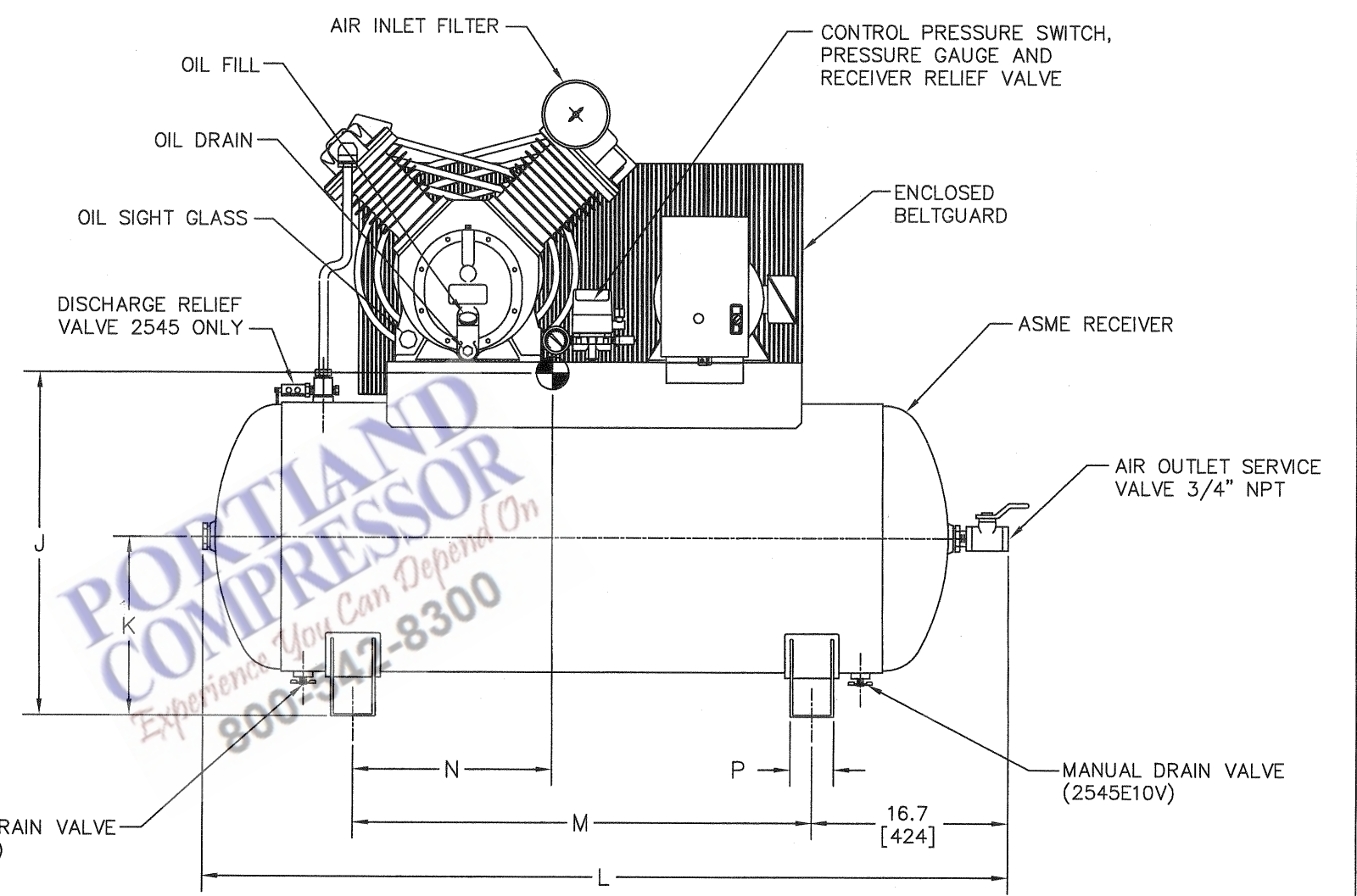
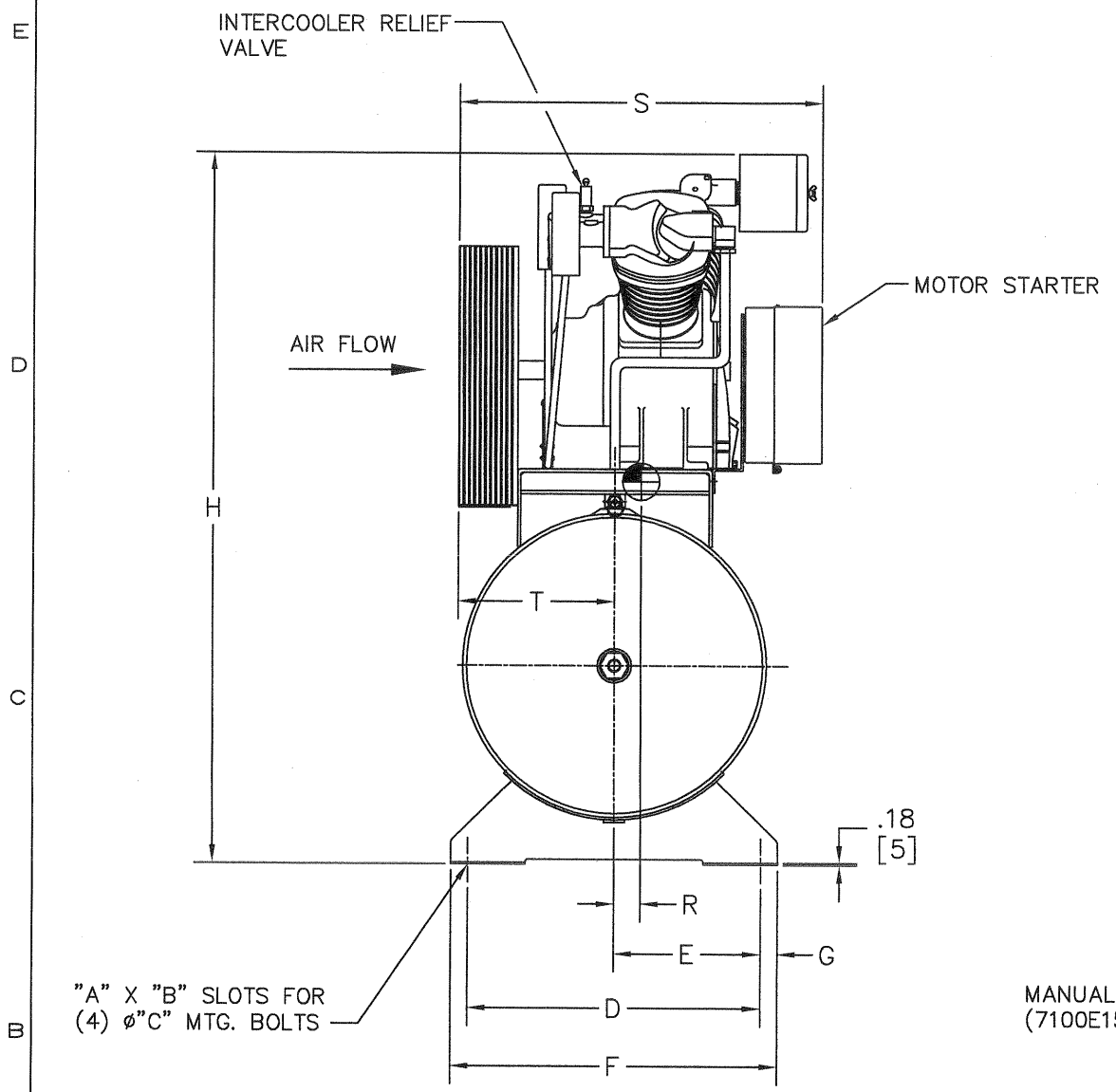

PORTLAND COMPRESSOR
 Experience You Can Depend On
 800-442-8300

- NOTES:
- FOUNDATION OR FLOOR MUST BE LEVEL AND SUPPORT ALL FEET EQUALLY; IF NECESSARY SHIM OR GROUT THE FOURTH FOOT.
 - FOUNDATION BOLTS SHOULD PROJECT THRU NUTS AT LEAST 1/2"[13] TO ALLOW FOR LEVELING.
 - ALLOW AT LEAST 12.00[305] CLEARANCE MIN. ON ALL SIDES FOR PROPER AIR CIRCULATION.
 - DIMENSIONS IN [] ARE MILLIMETER DIMENSIONS UNLESS OTHERWISE SPECIFIED.
 - ALL UNSPECIFIED TOLERANCES: XX = ±.25[6]
X = ±.50[13]
 - THE COMPRESSOR ARRANGEMENT SHOWN IS REPRESENTATIVE OF ALL THE UNITS LISTED.

| MODEL | NET WT. LBS [WT. KG] | RECEIVER | | | A | B | C | D | E | F | G | H | J | K | L | M | N | P | R | S | T |
|----------|-------------------------|---------------------------|-----------------|-------------|--------------|------|----------------|----------------|---------------|-------------|----------------|---------------|---------------|----------------|-----------------|---------------|--------------|--------------|---------------|---------------|---|
| | | SIZE IN. [SIZE mm] | GAL. [LITER] | | | | | | | | | | | | | | | | | | |
| 2545E10V | 900 [408] | 24" X 67" [610 X 1702] | 120 [454] | .69 [17] | 1.75 [44] | 1/2" | 20.19 [513] | 10.09 [256] | 23.6 [599] | 1.7 [43] | 49.9 [1267] | 24.1 [611] | 14.5 [368] | 70.8 [1798] | 42.00 [1067] | 18.1 [460] | 3.5 [89] | 3 [7] | 27.2 [691] | 11.3 [287] | |
| 7100E15V | 1035 [469] | 24" X 67" [610 X 1702] | 120 [454] | .75 [19] | 1.50 [38] | 1/2" | 23.75 [603] | 11.87 [302] | 26.5 [673] | 1.4 [36] | 57.1 [1450] | 29.7 [754] | 15.6 [396] | 71.7 [1821] | 42.00 [1067] | 17.5 [444] | 4.0 [102] | 1.82 [46] | 29.5 [749] | 12.8 [325] | |

| | | | |
|---|----------------|----------------------------|--|
| PROPRIETARY NOTICE <small>THIS DOCUMENT CONTAINS CONFIDENTIAL AND TRADE SECRET INFORMATION, IS THE PROPERTY OF INGERSOLL-RAND COMPANY, AND IS GIVEN TO THE RECEIVER IN CONFIDENCE. THE RECEIVER BY RECEPTION AND RETENTION OF THE DOCUMENT ACCEPTS THE DOCUMENT IN CONFIDENCE AND AGREES THAT, EXCEPT AS AUTHORIZED IN WRITING BY INGERSOLL-RAND COMPANY, IT WILL (1) NOT USE THE DOCUMENT OR ANY COPY THEREOF OR THE CONFIDENTIAL OR TRADE SECRET INFORMATION THEREIN; (2) NOT COPY THE DOCUMENT; (3) NOT DISCLOSE TO OTHERS EITHER THE DOCUMENT OR THE CONFIDENTIAL OR TRADE SECRET INFORMATION THEREIN; AND (4) UPON COMPLETION OF THE NEED TO RETAIN THE DOCUMENT, OR UPON DEMAND, RETURN THE DOCUMENT, ALL COPIES THEREOF, AND ALL MATERIAL COPIED THEREFROM.</small> | | THIRD ANGLE PROJECTION | |
| SCALE | NONE | DATE | 2009AUG03 |
| DRAWN | G.Levi | CHECKED | D.Adams |
| APPROVED | J.Ballard | DATE | 2009AUG03 |
| REF. | VALUE PACKAGES | TITLE | GENERAL ARRANGEMENT 2545E10V & 7100E15V |
| SIZE | A1 | DWG NO. | 45469848 |
| REV | A | SHEET 1 OF 1 | |